



JOY

la Galloccia Self Tailing
the Self Tailing Cleat

Cod. n° B1A241H

Rev 02.24

bonomi
earth and sea innovations





JOY B1A24H

DICHIARAZIONE CE DI CONFORMITA'
Conformity Declaration
(Allegato IIA DIR. 2006/42/CE)



IL FABBRICANTE / THE PRODUCED

Bonomi S.r.l

Azienda

Via Mario Pagano, 63

Indirizzo

Milano

Città

20145

Cap

Italia

Stato

MI

Provincia

DICHIARA CHE LA MACCHINA/Declar that the the Machine, code B1A241H 100kg 24v

GALLOCCIA MOTORIZZATA MOD. JOY/ The powered Cleat JOY, code B1A241H 100kg 24V

Descrizione / Description

Matricola / Serial N°

Anno costr. / Construction Year

Adatta a favorire l'ormeggio delle imbarcazioni / Suitable for boat mooring

Uso previsto / USE

SODDISFA LE DISPOSIZIONI DELLA DIRETTIVA /MEETS THE PROVISIONS OF THE DIRECTIVE

2006/42/CE del Parlamento europeo e del Consiglio, del 17 maggio 2006 relativa alle macchine e che modifica la direttiva 95/16/ CE.

E AUTORIZZA / and Authorize

Cristiano Bonomi

Nominativo

Via Mario Pagano, 63

Indirizzo

Milano

Città

20145

Cap

Italia

Stato

MI

Provincia

A COSTITUIRE IL FASCICOLO TECNICO /To Provide the Technical File

Milano ,/...../.....

Il fabbricante



(timbro e firma del Responsabile)

BONOMI srl
Soc. Unipersonale

Head Office
Via Mario Pagano, 63
20145 Milano
Italy
C.F. P.IVA IT09477540968

Facility
Via B. Salvadori, 34
15011 Acqui Terme (AL)
Italy

Contact
www.bonominet.it
info@bonominet.it



JOY B1A24H

INDEX

pag. 8-29

MANUALE DI INSTALLAZIONE
INSTALLATION MANUAL

pag. 30-35

**MANUALE D'USO E MANUTENZIONE
E PRECAUZIONI DI SICUREZZA**
*USE AND MAINTENANCE MANUAL
AND SAFETY PRECAUTIONS*

JOY B1A241H

LEGGERE ATTENTAMENTE!
READ CAREFULLY!

JOY B1A24H

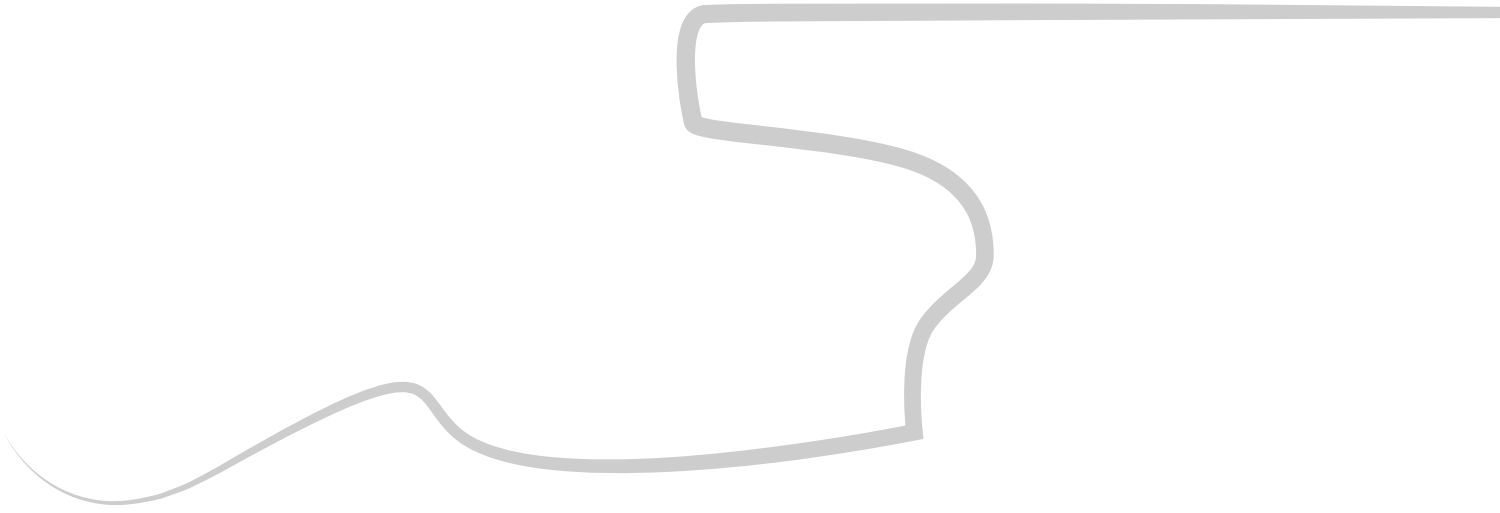



MANUALE DI INSTALLAZIONE

INSTALLATION MANUAL

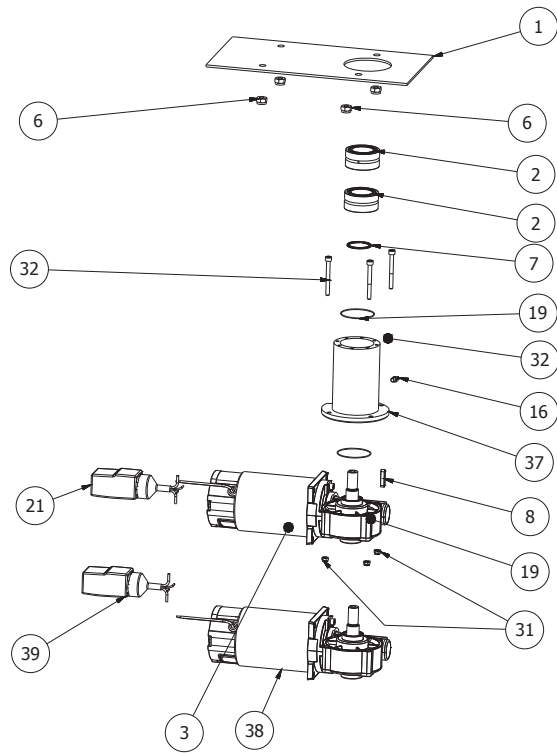
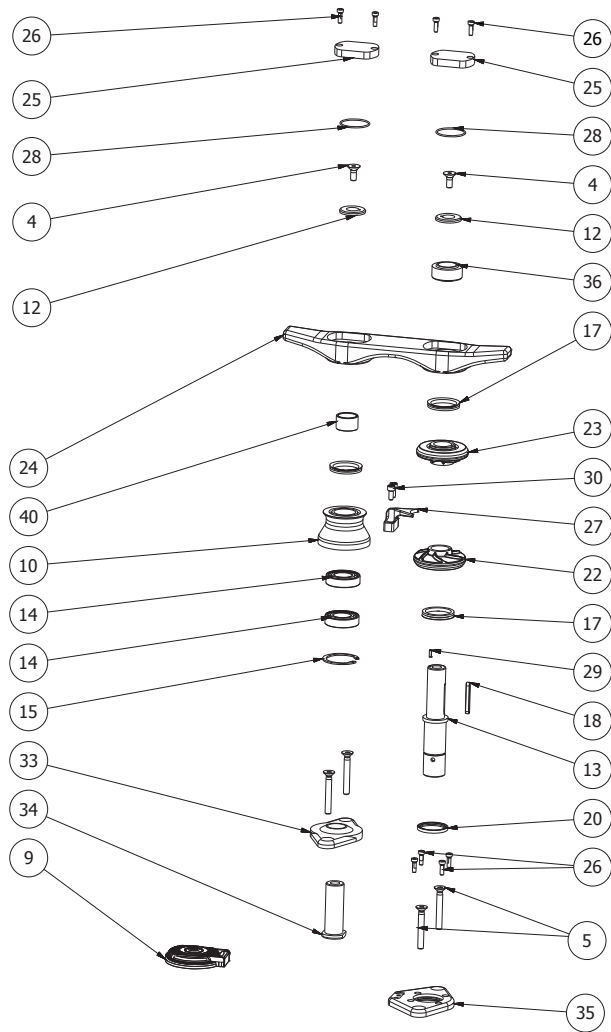

40	1	SPACER	B1A242H039
39	1	SINGLE POLE CONTACTOR 12 Volts	B3A242H002
38	1	MOTOR GEARBOX 12 Volts	B3A242H001
37	1	BEARING GEAR BOX FLANGE	B1C241H013
36	1	SPHERICAL JOINT di 25 De 42 B 20	B1A242H104
35	1	BASE SUPPORT FLANGE	B1A242H103
34	1	FIXED SHAFT	B1A242H102
33	1	FIXED SHAFT FLANGE	B1A242H101
32	3	SOCKET HEAD CAP SCREW ISO 4762 M5 X 50	B1A242H100
31	3	LOOK NUT M5 ISO 10511	B1A242H099
30	2	SOCKET HEAD CAP SCREW M6x14 ISO 4762	B1A242H097
29	1	SPRING PIN 3x10 ISO 8752	B1A242H091
28	2	O-RING Øi=37.82 COSS SECTION 1.78	B1A242H087
27	1	STRIPPER	B1A242H083
26	8	SOCKET HEAD CAP M5x16 DIN 6912	B1A242H082
25	2	COVER	B1A242H081
24	1	TOP PLATE	B1A242H080
23	1	UPPER ROPE RING	B1A242H079
22	1	UPPER ROPE RING	B1A242H078
21	1	SINGLE POLE CONTACTOR 24 Volts	B1A242H065
20	1	SEALING RING G35X42X4 SINGLE LIP	B1A242H060
19	2	O-RING Øi=45 CROSS SECTION Ø 1	B1A242H059
18	1	KEY UNI7510-A 8x5x45	B1A242H056
17	3	V-RING FOR SHAFT Ø 36-38	B1A242H052
16	1	GREASE NIPPLE M6x1 UNI 7663-A	B1A242H050
15	1	RETAINING RING J47 DIN 472	B1A242H047
14	2	BEARING,SINGLE ROW W6005-2RS1	B1A242H045
13	1	MOBILE SPINDLE	B1A242H044
12	2	SEALING WASHER	B1A242H041
10	1	ROLLER	B1A242H038
9	1	FOOTSWITCH	B1A242H022
8	1	KEY UNI 6604-A 5x5x25	B1A242H020
7	1	RETAINER RING DNS 30-S16	B1A242H018
6	4	HEXAGON. LOCKNUT ISO10511-M8-A4	B1A242H016
5	4	LOBULAR COUNTESUNK SCREW M8 x 60 ISO 14581	B1A242H015
4	2	COUNTERSUNK HEAD SCREW UNI 5933-M8x20-A4	B1A242H014
3	1	MOTOR GEARBOX 24 Volts	B1A242H013
2	2	BEARING RADIAL/AXIAL d= 30 mm D=47 mm B=23 mm	B1A242H012
1	1	LOWER PLATE	B1A242H008
Number	Qty	Description	Part number

24 volts ASSY CLEAT COD.N. B1A241H SEE BIL OF MATERIAL
 12 volts ASSY CLEAT COD.N. B3A121H SEE BIL OF MATERIAL

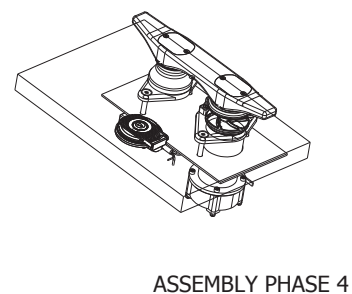
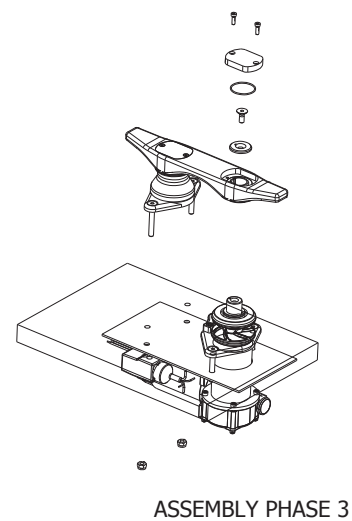
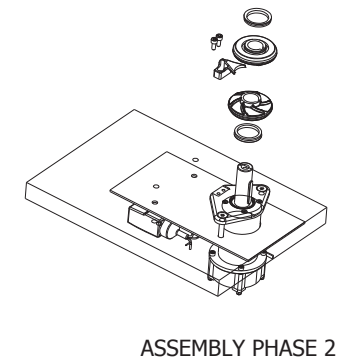
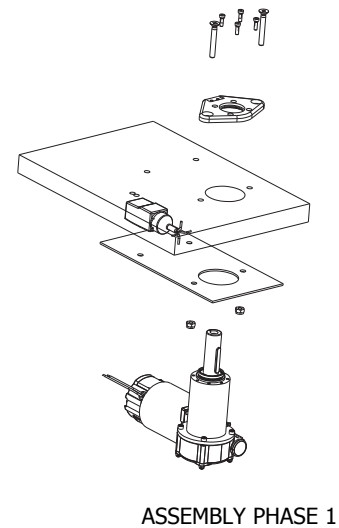



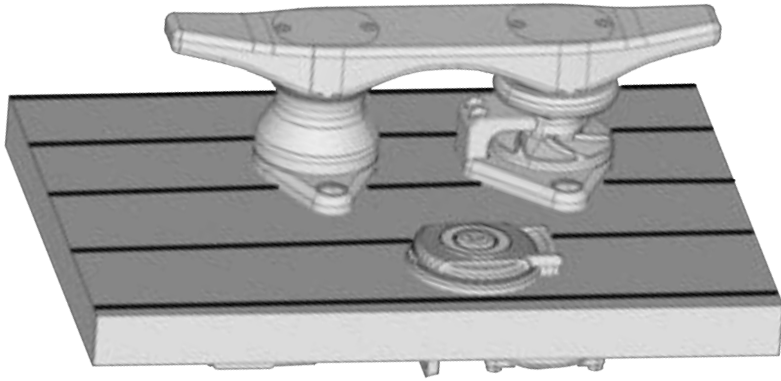

ATTREZZATURA NECESSARIA PER L'INSTALLAZIONE DI JOY

EQUIPMENT NEEDED TO INSTALL JOY

- _ Trapano elettrico professionale.
Professional electric drill.
- _ Punta da trapano per metalli: 9 mm
Metal drill bit Hss-R: OD 9 mm
- _ Chiave combinata per dado: 13 mm
Combined wrench Key: OD 13 mm
- _ Chiave a brugola: 5 mm
Allen wrench key: 5 mm
- _ Chiave a brugola: 4 mm
Allen wrench key: 4 mm
- _ Cacciavite a taglio
Screw driver : flat head (-)
- _ Sega a tazza: 65 mm
Hole saw: OD 65 mm
- _ Grasso raccomandato per cuscinetti e guarnizioni.
Reccomended Grease for bearing and gasket:
Synthetyc bearing and gear grease for nautial application
 - SKF-LGM 2
 - Molikote
 - SMW Autoblock - K50

SUGGERIMENTI DI POSIZIONAMENTO SUL PONTE

DECK INSTALLATION GUIDE LINE

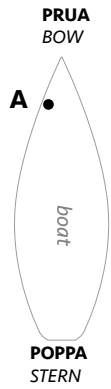
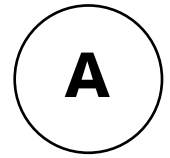

PRUA - SINISTRA
BOW - LEFT

NEUTRAL PULLEY

MOTOR PULLEY

SELF TAIL

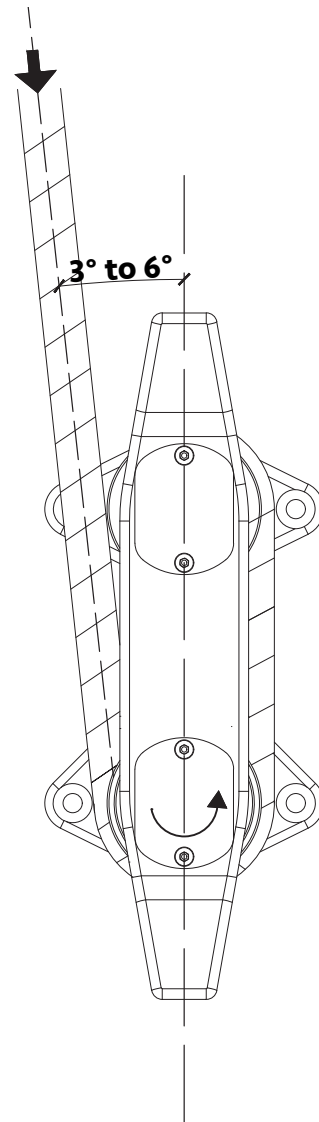
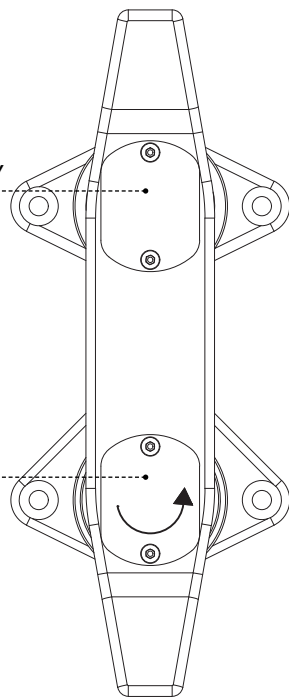

JOY B1A241H

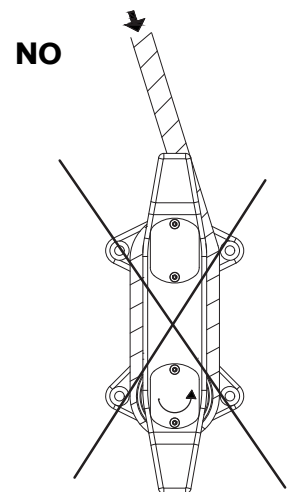
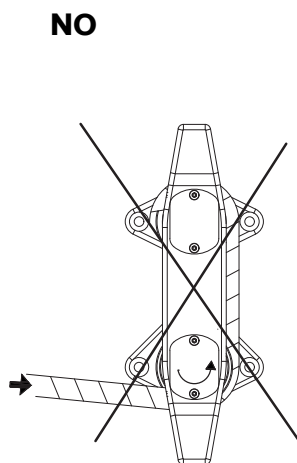
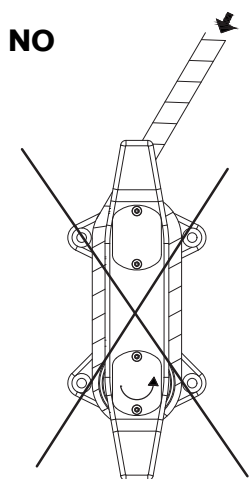
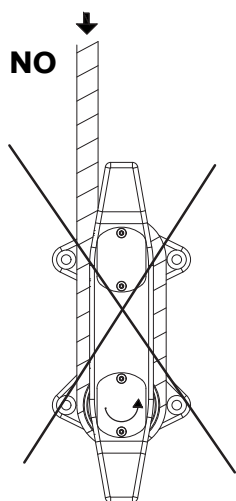

SUGGERIMENTI DI POSIZIONAMENTO SUL PONTE

DECK INSTALLATION GUIDE LINE

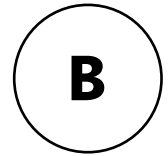

PRUA - DRITTA
BOW - RIGHT

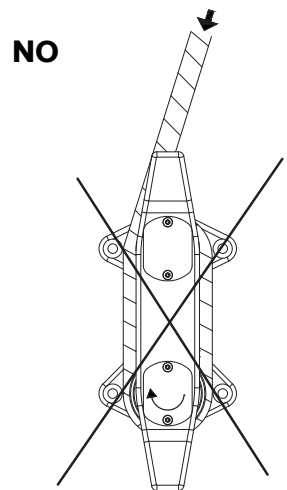
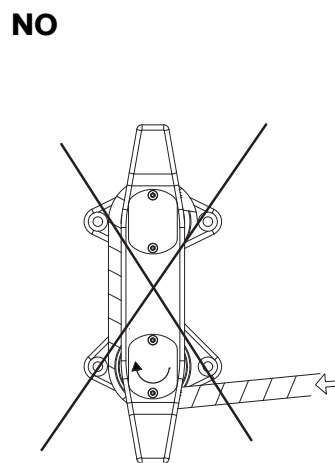
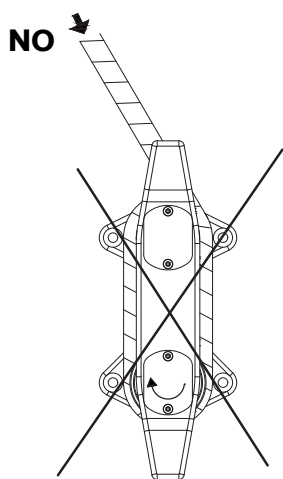
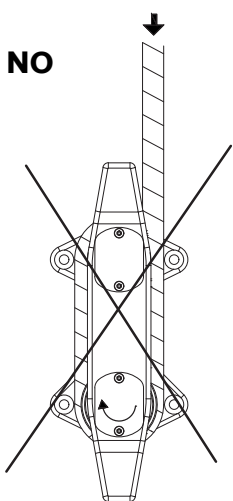
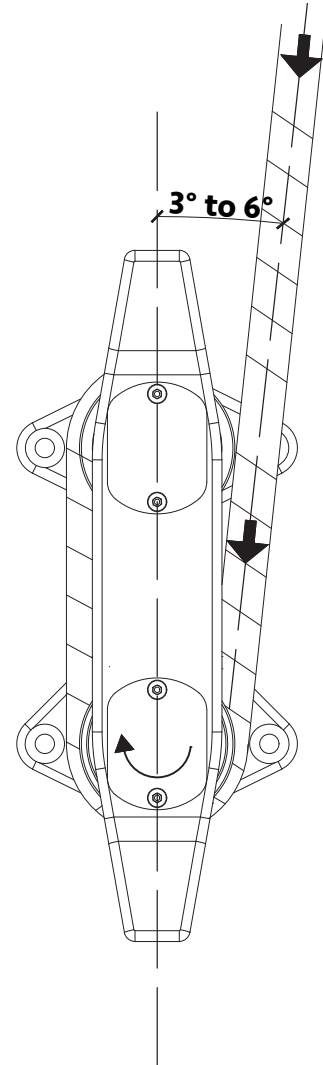
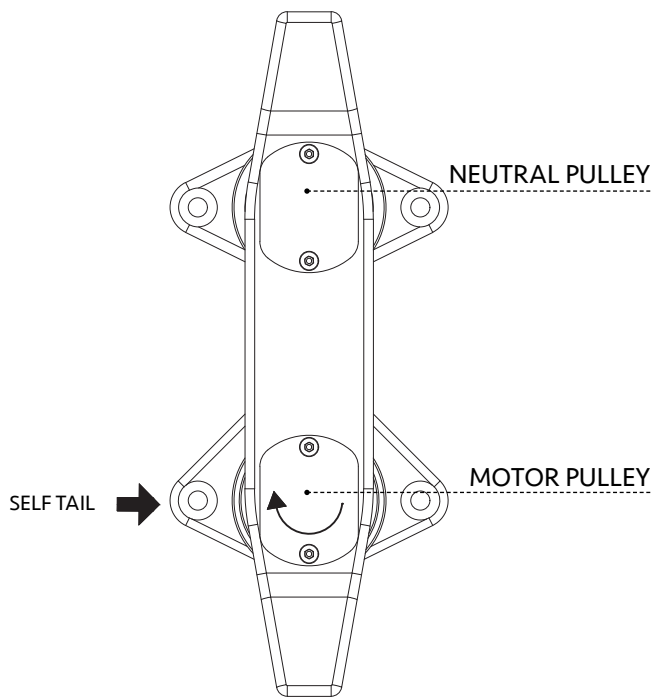

JOY B1A241H

SUGGERIMENTI DI POSIZIONAMENTO SUL PONTE

DECK INSTALLATION GUIDE LINE

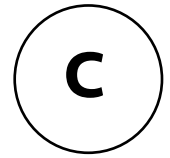

POPPA - SINISTRA STERN - LEFT

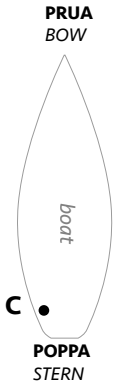

MOTOR PULLEY

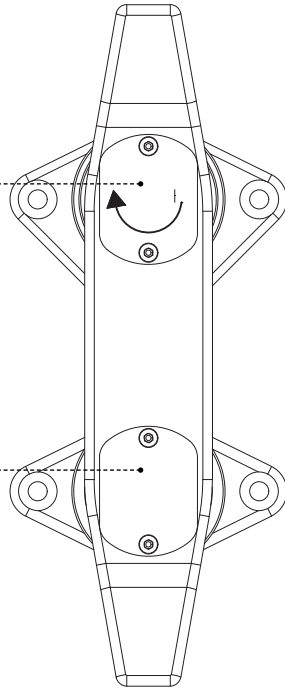

SELF TAIL

NEUTRAL PULLEY

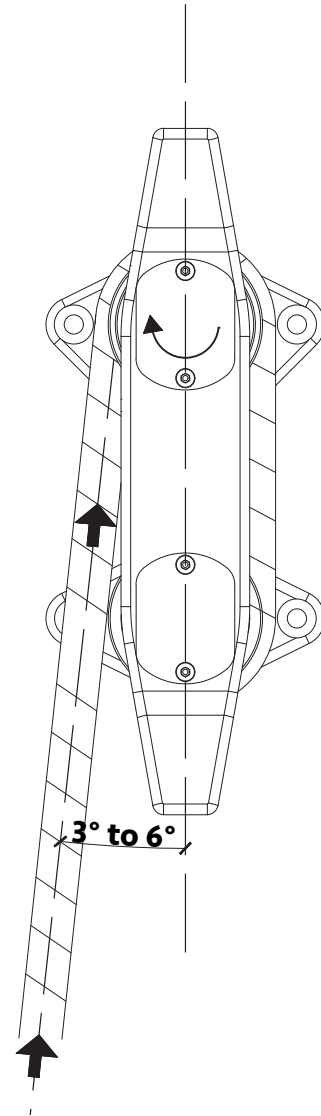

3° to 6°

JOY B1A241H

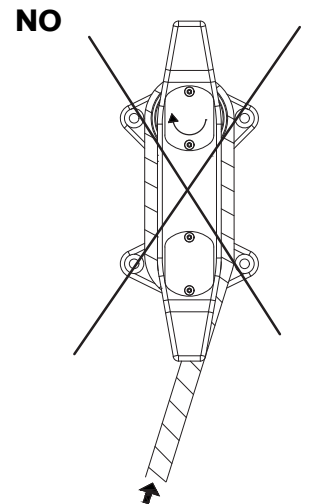
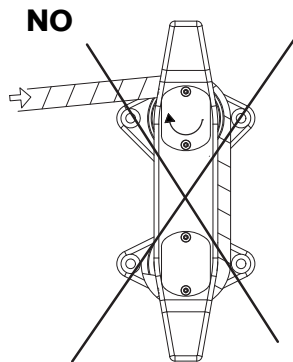
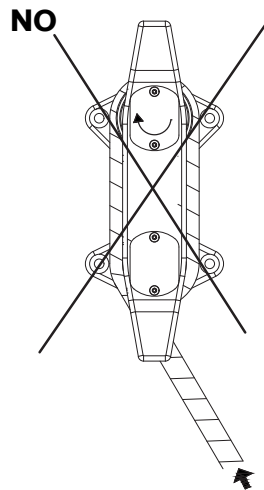
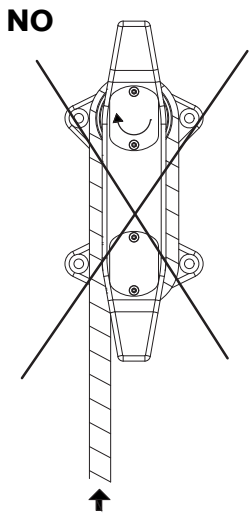

SUGGERIMENTI DI POSIZIONAMENTO SUL PONTE

DECK INSTALLATION GUIDE LINE

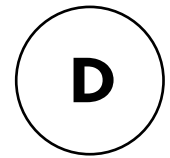

POPPIA - DRITTA
STERN - RIGHT

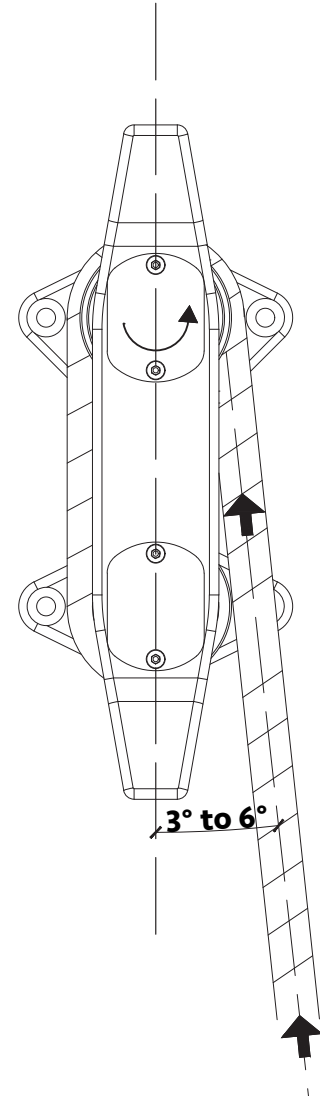
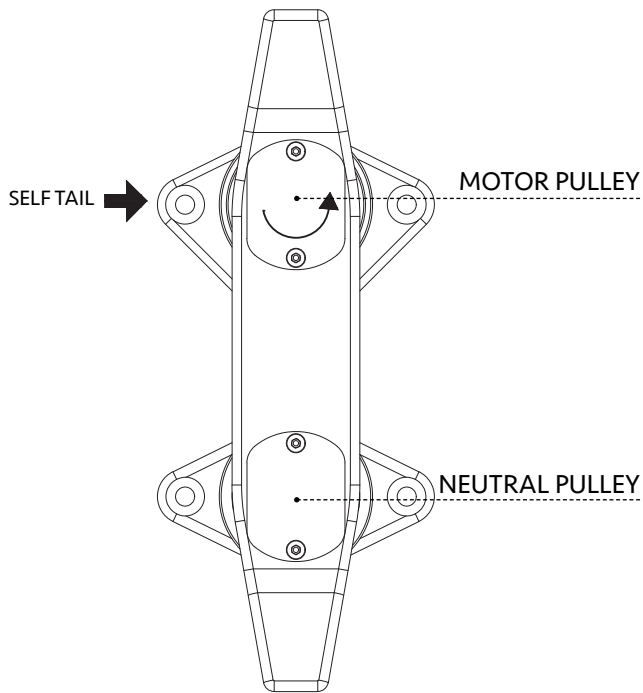
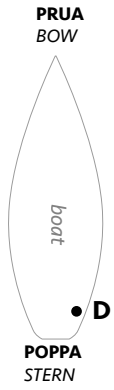

JOY B1A241H

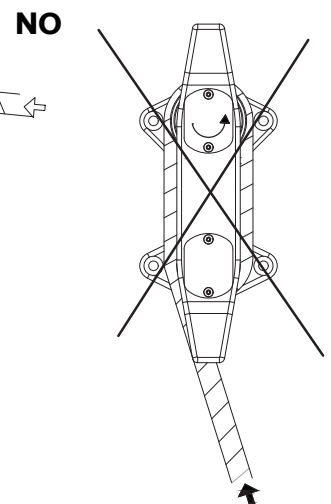
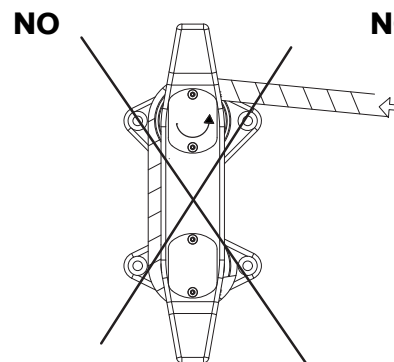
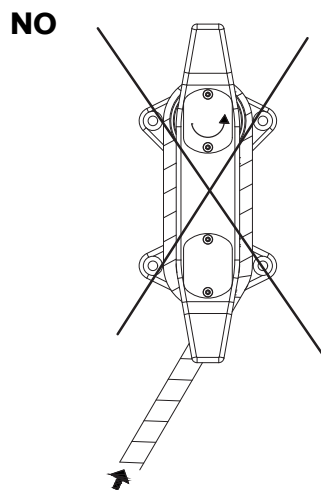
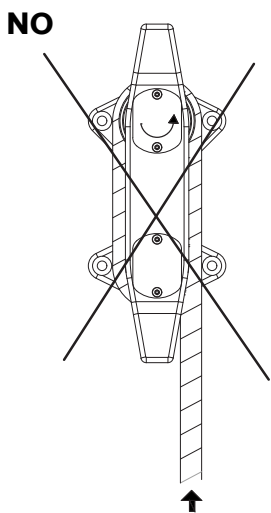

1) PREPARAZIONE E POSIZIONE

POSITION AND PREPARATION

Preparazione posizione.

Rimuovere le attrezzature vecchie e togliere tutte le asperità della zona di installazione.

NOTA: JOY è una attrezzatura elettro meccanica deve essere installata professionalmente al fine di ottenere una migliore e piu duratura vita.

Position preparation. Remove the old equipment and all the bumps in the area of installation.

NOTE: JOY is an electro-mechanical equipment must be installed professionally in order to achieve a better and more sustainable life.



2) PULIZIA PONTE PRIMA DEL MONTAGGIO

DECK CLEARING BEFORE ASSEMBLY

Il ponte deve presentare un piano liscio senza scalini o asperità, l'installazione di JOY su un ponte non piatto compromette la sua funzionalità.

The deck must have a smooth plane without steps or haze, JOY installation on a non-flat deck compromises its functionality.





3) CONTROPIASTRA DI FISSAGGIO USATA COME DIMA

COUNTERPLATE USED AS MOUNTING TEMPLATE.

NB: Il posizionamento di JOY deve essere studiato bene prima dell'esecuzione dei rispettivi fori di fissaggio sul ponte. L'asse longitudinale di Joy deve essere riferito e posizionato, in base al ponte stesso e alla direzione di arrivo della cima di ormeggio.

Please note JOY positioning must be well studied before the respective fixing holes on the deck are executed. Joy's longitudinal axis must be reported and positioned, according to the deck itself and the direction of arrival of the mooring line.



**ATTENZIONE!!
WARNING!!**



**!! NOTA IMPORTANTE
VEDERE PAG. da 14 a 17**

*SEE IMPORTANT NOTE
PAGE from 14 to 17*

IMPORTANTE:

Il posizionamento e i fori sul ponte sono due passaggi fondamentali! Siete pregati di pensare molto bene al posizionamento della vostra JOY sul ponte prima di eseguire i fori!
(vedi pag. da 14 a 17)

IMPORTANT:

positioning and holes on the deck are two fundamental steps! Please think very well about positioning your JOY on the deck before running the holes!
(see pages from 14 to 17)

4) ESECUZIONE DEI 4 FORI PERIMETRALI PER FISSAGGIO JOY

EXECUTION OF 4 PERIMETER HOLES FOR FASTENING JOY TO THE DECK.

NOTE

Prima di forare il ponte assicurarsi di aver ben compreso e ragionato sulla posizione dei fori.

Before drilling the deck make sure you well understand the positioning of the hole you are doing.

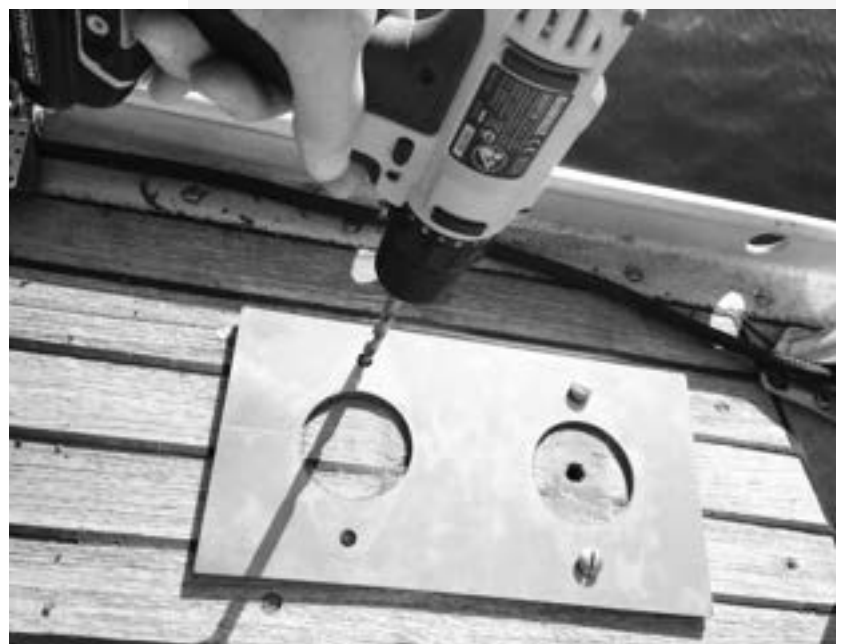



5) FORO CENTRALE PER ASSE MOTORE

CENTRAL HOLE FOR MOTOR AXIS

Prima di forare il ponte assicurarsi di aver ben compreso e ragionato sulla posizione dei fori.

Before drilling the deck make sure you well understand the positioning of the hole you are doing

JOY B1A241H



6) POSIZIONAMENTO SOTTO IL PONTE DELLA CONTRO PIASTRA DI FISSAGGIO

UNDER DECK CONTERPLATE POSITIONING

Per fissarla temporaneamente vi suggeriamo di utilizzare una vite di posizione ⑤.

To fix it temporary, we suggest you to utilize and screw of positioning ⑤.



**7) POSIZIONAMENTO MOTORIDUTTORE
PREASSEMBLATO SOTTO COPERTA**

*PRE-ASSEMBLED POSITIONING GEARMOTOR
UNDER DECK*



Ricordare di posare
la contropiastra!

*Remember to install
the counter plate!*

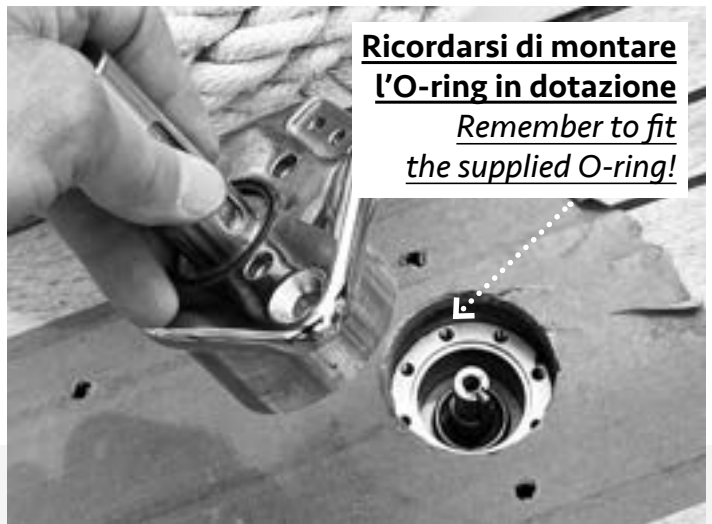
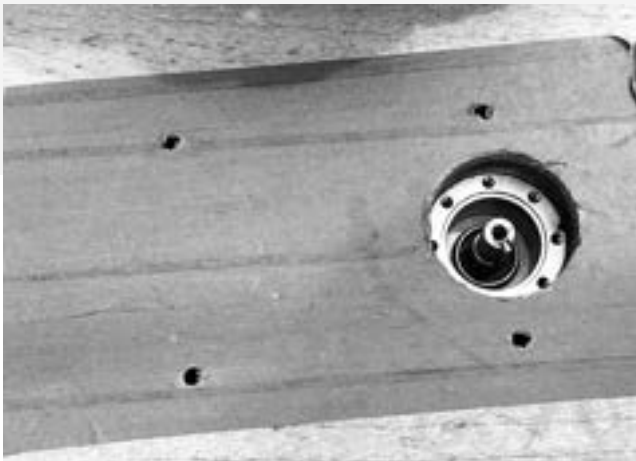

**Ricordarsi di montare
l'O-ring in dotazione**

*Remember to fit
the supplied O-ring!*

**8) FISSAGGIO A BULLONI DEL MOTORIDUTTORE
ALLA COPERTA TRAMITE PARTE SUPERIORE PRE
ASSEMBLATA**

*FIXING THE GEARMOTOR TO THE DECK VIA THE
FIRST UPPER BASE WITH SCREW*

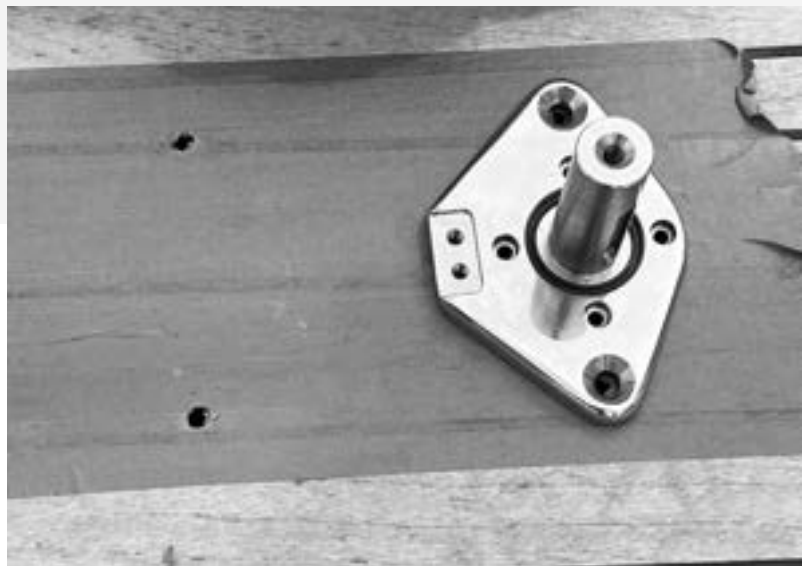

JOY B1A241H

9) FISSAGGIO A BULLONI DEL MOTORIDUTTORE CON LA PARTE SUPERIORE ALLA COPERTA

FIXING THE GEARMOTOR BOLT TO THE UPPER DECK PART

Utilizzare viti di posizione (33).

Utilize screw of position (33).



JOY B1A241H

10) INSERIMENTO SELF TAIL INFERIORE

LOWER SELF-TAIL POSITIONING

Il Self Tail è munito di guarnizioni di tenuta in gomma vulcanizzata, è buona cosa spalmare con grasso apposito suggerito.

NOTE: I Self-Tail sono studiati per essere montati in coppia e orientati in base alla rotazione del motore per avere la cima di ritorno orientata verso il centro dell'imbarcazione o verso l'esterno in tutte e due i casi JOY non perde la funzionalità.

NB: Ragionare bene sul senso di rotazione del Self Tail in funzione del rimando della cima.

The Sel-Tail is fitted with vulcanized rubber sealing gasket, good thing is spread with a special recommended gear grease.

The Self-Tail are designed to be mounted in pairs and oriented to the rotation of the motor to have the return rope oriented towards the boat center or outdoors in all case JOY not lose functionality.

NB: Think very well about the direction of the self tail rotation as a function of the rope back direction

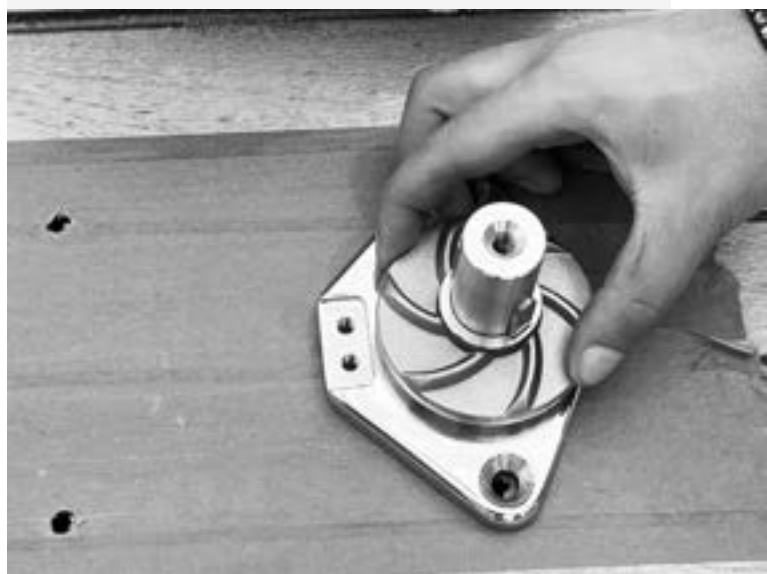

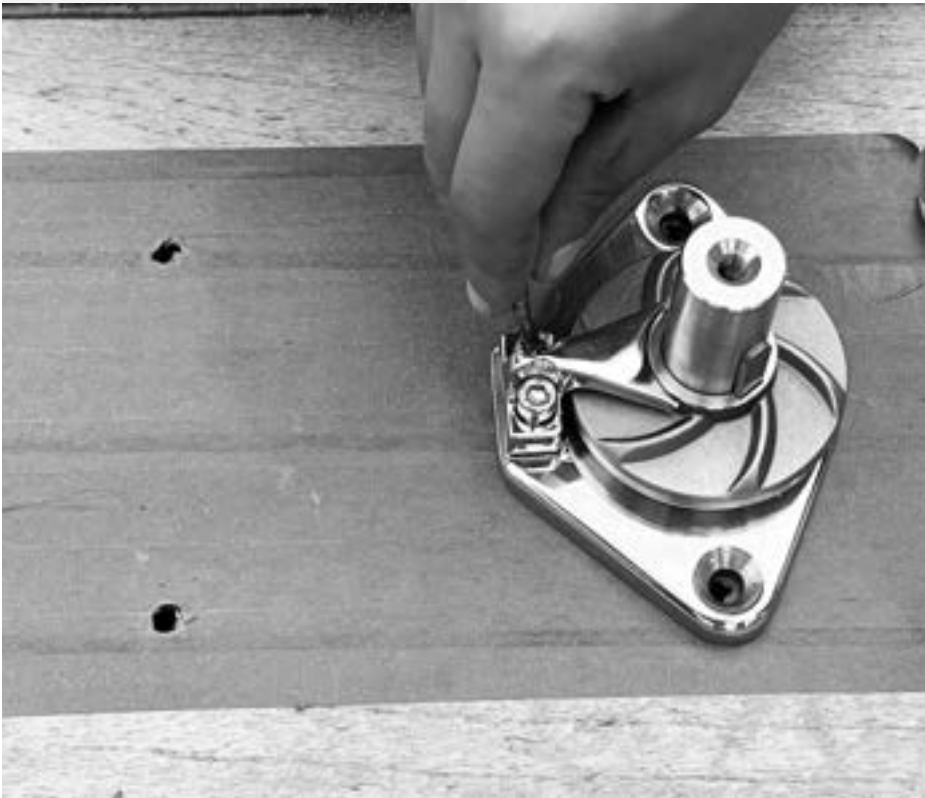

11) POSIZIONAMENTO STRIPPER
LINE STRIPPER POSITIONING

12) BLOCCAGGIO STRIPPER ARM
ALLA BASE CON VITI DI POSIZIONE 32

STRIPPER ARM LOCK
AT THE BASE WITH SCREW OF POSITION 32

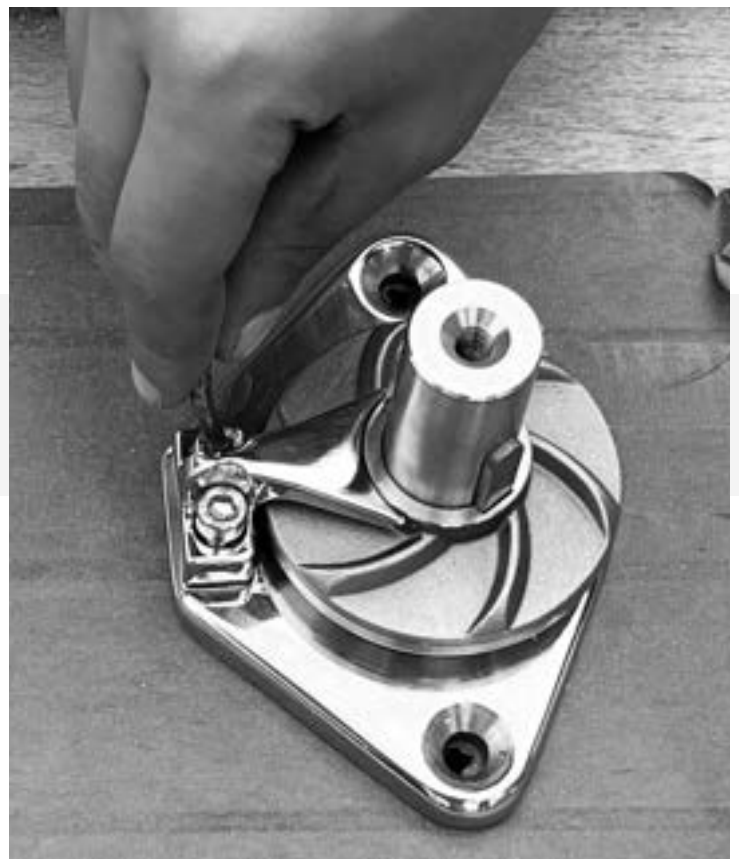



13) INSERIMENTO SELF-TAIL SUPERIORE

UPPER SELF-TAIL POSITIONING

Il Self Tail è munito di guarnizioni di tenuta in gomma vulcanizzata è buona cosa spalmare con grasso suggerito.

La mancanza di grasso compromette la durata delle guarnizioni

The Sel- Tailing is fitted with vulcanized rubber sea- ling gasket good thing is spread with a special recommended grease.

Lack of grease compromises the life of the gasket.



JOY B1A241H

14) INSERIMENTO DELLA PARTE PREMONTATA

INSERT OF THE PREASSEMBLED PART

L'inserto dell'asse motore sul giunto sferico deve essere fatto con attenzione, pulendo e ingrassando le parti con il grasso raccomandato.

The drive shaft insert on the spherical joint must be done carefully, clearing and greasing the parts with the recommended grease.





**15) INSERIMENTO SPINA ELASTICA
ANTI ROTAZIONE RONDELLA DI TENUTA**
*WASHER ANTI-ROTATION ELASTIC PIN,
TO BE INSERT BEFORE FIT THE SCREW*



16) COLLEGAMENTO E FISSAGGIO ALL'ALBERO
CONNECTING AND FITTING TO THE SHAFT

NB: La manovra di serraggio delle viti in posizione ④ deve essere eseguita prima della manovra indicata ai punti 17) e 18).

NB: the fixing of the screws in position ④ must be carried out before the maneuver indicated in steps 17) and 18).

NB! I due fori di fissaggio del corpo coperchio sono filettati M5 per consentire la futura estrazione, senza danneggiare il coperchio apposito.

The two fixing hole of the cover are M5 threaded to allow the future extraction without damaging the cover

17) CHIUSURA CUSCINETTO DI ROTAZIONE.

ROTARING BEARING CLOSURE

Riempire le parti con grasso suggerito, prima della chiusura del giunto sferico con il coperchio apposito tramite viti di posizione (34).

NB: Questa manovra può anche essere eseguita al termine.

Fill the part with the recommended grease before closing the spherical joint, with the cover using screw of position (34).

NB: This operation could be done as final operation

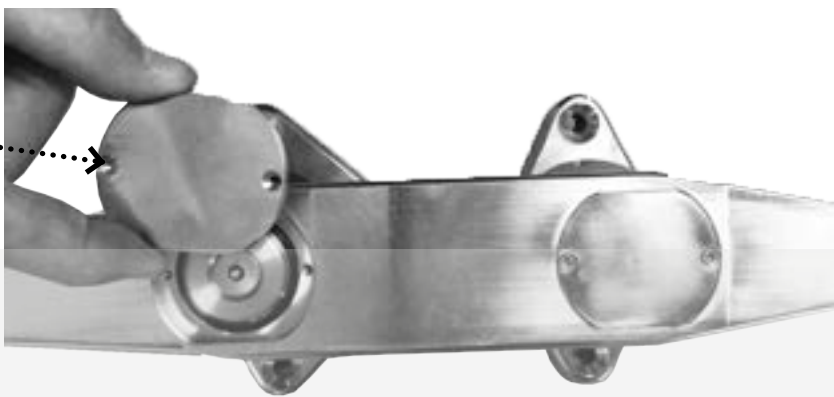

18) PRIMA DEL SERRAGGIO ALLA COPERTA INSERIRE UNA GUARNIZIONE LIQUIDA

INSERT A LIQUID GASKET BEFORE TIGHTENING TO THE DECK

Suggeriamo per praticità di posizionare la guarnizione liquida (tipo sikaflex) alla fine del montaggio e prima di serrare le quattro viti di posizione (5).

We suggest you to position the liquid seal (for ex. sikaflex) at the end of the assembly e before fixing the four screw of position (5).

19) SERRAGGIO FINALE ALLA COPERTA

FINAL FIXING TO THE DECK

Prima del serraggio delle viti di posizione ⑤, inserire la guarnizione liquida in entrambi gli appoggi di JOY al ponte. A viti serrate eseguite le manovre finali dei punti 15) e 16).

Before fixing the screw of position ⑤, insert the liquid seal on both JOY's supports to the deck. After fixing the screws, do the final operations 15) and 16)

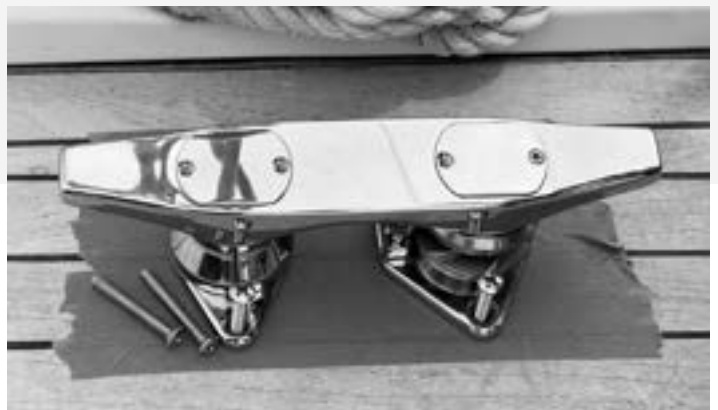

JOY BTA24TH

INGRASSATORE
GREASE NIPPLE



20) STEP FINALE

FINAL STEP

Al termine, ingrassare a pieno l'albero rotante tramite apposito ingrassatore usando grasso blu marino.

At the end, full fill the rotating shaft via the grease nipple with the recommended gear grease.

COLLEGAMENTO ELETTRICO SECONDO SCHEMA

ELECTRICAL CONNECTION ACCORDING TO SCHEME

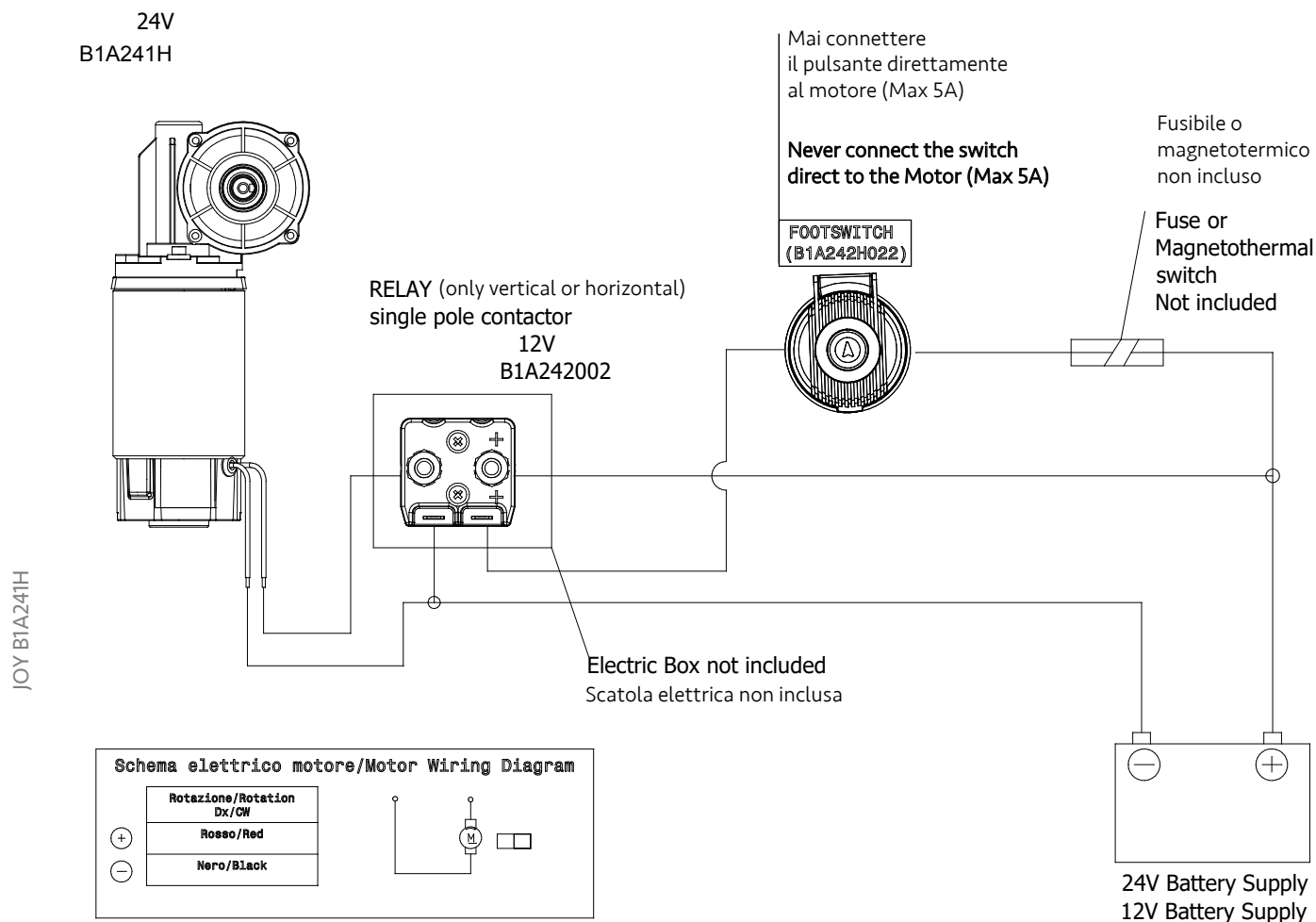

ATTENZIONE IMPORTANTE!

Durante l'ancoraggio a cima tesata e quindi a tensione massima, non insistere con il pulsante di comando, potreste danneggiare irreversibilmente il motore o altri apparati elettrici!

IMPORTANT WARNING

While mooring and when the line will be tensioned to the max, do not insist switching on the electrical power, you could damage the motor and or other electrical equipment!

ENJOY WITH JOY

Complimenti, avete installato la vostra *JOY* correttamente e da ora in avanti la utilizzerete per i Vs ormeggi senza piu tirare le cime sino a farvi venire o il mal di schiena o di mani.

Congratulation, you installed your JOY correctly, and from now on you will use it for moorings without pull the line, avoiding back and hands pain.

JOY B1A24H

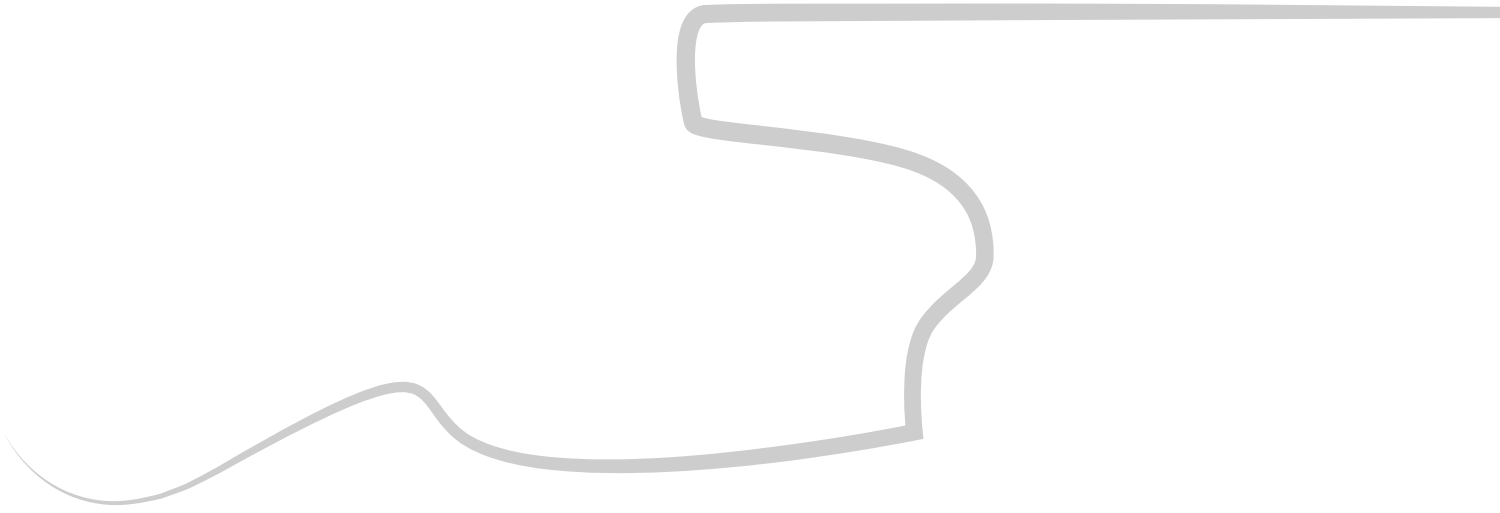



MANUALE D'USO E MANUTENZIONE E PRECAUZIONI DI SICUREZZA

USE AND MAINTENANCE MANUAL AND SAFETY PRECAUTIONS

IMPORTANT:

Please carefully read the instruction contained in this manual before putting the unit into operation

This product has been designed and produced respecting high production standards to guarantee excellent performance, convenient use and operator safety. If used with the utmost care, this product will guarantee years of optimum performance

GENERAL SAFETY RULES

ATTENTION

Carefully read all safety instructions and warnings. Failure to follow the warnings and instructions may result in electric shock, fire and serious injury.

USE FOR

This mooring motorized is equipped with a mechanical retention of the mooring line and is indicated to facilitate the maneuver of mooring in the port of the boat. This product is only suitable to favor the tension of the bow and/or stern lines of the boat and to favor the mooring phase is not to be considered as a winch or towing system.

TYPOLOGY OF USER: this product is intended for use by consumers, even non-professional maritime operators and is recommended for people of legal age.

Do not use the product for any purposes not indicated. The product should not be used as a fatigue tool. The product must not be used by children or by non-experts in the sector, the equipment is not designed for an ongoing function.

RESIDUAL RISKS

Even indicating clearly what is the intended use for this product there are always unforeseeable residual risks. Depending on the type and construction of the product the following risks may occur:

- *Contact with rotating parts of the product, risk of abrasion and fractures*
- *Sudden and unexpected movement of the boat due to excessive tension, risk of falling, with potential fracture and abrasions*
- *Interweaving of cloche or different tops with rotating parts, risk of abrasion and potential fracture*
- *Hand skin contact, abrasion risk*
- *Keep this manual for future reference. The term "electrical appliance" used in the warnings refers to electrical appliances to be connected to the boat network, to the indicated voltage.*
- *Connections at higher voltages may cause short circuits with corresponding potential fire principles and baking of the electric motor*

SAFETY IN THE WORK ENVIRONMENT

- *Keep the workplace clean and well lit. The cluttered spaces and poorly lit are source of accidents.*
- *Do not use the product in potentially explosive environments such as petrol cans or gas cylinders*
- *We suggest to think well before starting with the installation of the product that is simple, but the help of a specialized technician, electrician is strongly suggested*

ELECTRICAL SAFETY

- *Prevent the body from coming into contact with grounded metal surfaces such as power cables*
- *Do not expose the electric motor to direct water source, it favors the risk of electric shock, short circuits and fires*

PERSONAL SAFETY

- *Always remain vigilant; when using an electrical appliance, always pay attention to the operations to be carried out and always use common sense. Do not use the equipment in case of fatigue, under the effect of alcohol or drugs. Never forget that a moment of distraction is enough to cause serious injury*
- *Avoiding or minimizing involuntary start-ups due to or interlocking the footswitch or malfunctions of the system, the equipment is not designed to remain in constant motion.*
- *Before starting up the equipment and during its normal use, make sure that there are no foreign bodies that can block or compromise his operational.*
- *Do not extend the arms excessively by placing your hands close to the motorized rotating pin to prevent them from becoming involuntarily entangled in the mechanism*
- *Avoid intertwining the mooring lines with clothes, bracelets, necklaces or other that can create the situation of clinging and dragging towards the rotating motorized part*

USE AND MAINTENANCE OF ELECTRICAL APPLIANCES

- *Do not force the appliance. Use the appliance appropriate for the work to be done. The appliance will offer better performance and will be safer when used in the system for which it has designed.*
- *Do not use the appliance if the switch does not allow it to start and stop correctly. A device that can not be switched on and off properly is dangerous and must be completely repaired.*
- *Disconnect the appliance from the power supply before making adjustments or changing spare parts. These preventive safety measures reduce the risk of accidental switching on of the appliance with consequent damage to property and persons.*
- *Check the status and functionality of the electric motor to avoid electric shocks*
- *Observe the working conditions and the operations to be carried out while using the appliance. To avoid dangerous situations, use the electric appliance only for the work for which it was designed*
- *Do not underestimate that the JOY has the same function as a normal known cleat but is powered by a geared motor is therefore to be considered as a machine and as such should be treated, especially in respect of potential damage to property and people*

MAINTENANCE

- Any repairs must be carried out by a qualified technician, who, we suggest, must use only original spare parts. Maintenance requires a two-year verification of rotating parts and seals; annually insert the grease indicated on the vulcanized rubber seals in order to increase its life, grease the gearmotor body every year.

GENERAL SAFETY REGULATIONS

- Before start control the sense of rotation of the shaft in order to make the equipment work properly
- With the rope in the hand and not in tension, position it correctly, giving once around the two rotating pins of the equipment
- Position yourself with wide legs in a comfortable position in order to perform the maneuver in safety while maintaining a firm position to keep the return top stretched to facilitate maneuvering.
- Open the safety cover of the foot switch in order to carry out the top tension operation constantly and without interrupting it.
- Pay attention during the final tension phase of the rope avoiding to bring it to a condition of excessive tension and breaking, in order to avoid damage to things and people.

SPECIFICATIONS

Model	B1A241H
Voltage	24V DC
Duty:	S2 5min
Watt:	230
RPM to the slowdown shaft:	60
Torsion to the slowing shaft:	25-30 Nm
Max speed :	6,5 m/min
Load in work on the reducer:	1100 N—110 kg
Maximum load on gearbox:	1428-1714 n—145-175KG*
Ins.Class:	F
Protection:	IP 44
Oil gerabox:	ISO 150 PA0
Weight tot kg:	11,5
Mooring Line section min-max mm:	20 - 32

* in reference to the line OD

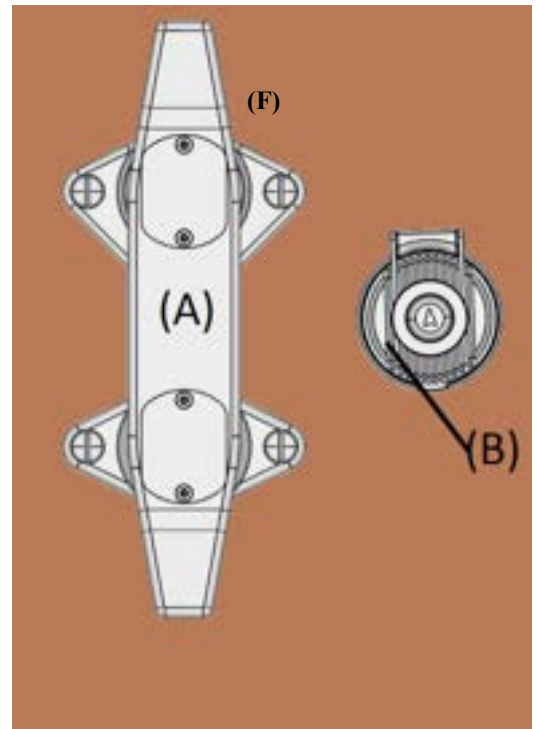
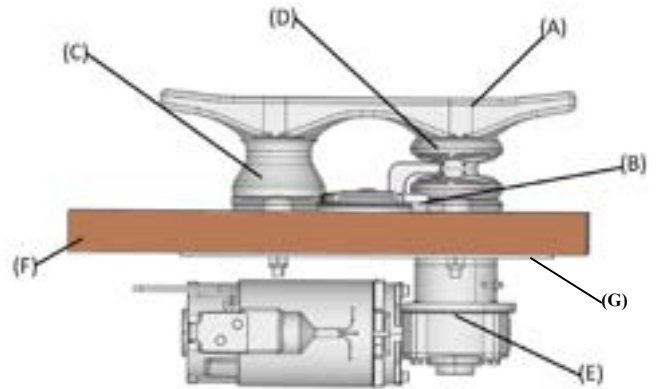

JOY B1A241H

(A)	Top plate
(B)	Footswitch
(C)	Neutral rotating pin
(D)	Motorized rotating Self Tail
(E)	Under deck motorgearbox
(F)	Deck
(G)	Lower plate

PRODUCT INFORMATIONS

- External part AISI 316L
- Rotary part— secondary shaft—sealed bearing, primary shaft in grease immersion camera
- Motorgearbox IP 44
- Foot switch in printed polymer IP 67
- Gear motor shaft rotation parts with grease bath
- Seals on rotating parts made of highe-strength vulcanized rubber

GENERAL INFORMATIONS

For any request, contact the technical office of Bonomi srl

Head Office: Via Mario Pagano, 63 - 20145 Milano (MI)
 Facility: Via B. Salvadori, 34 - 15011 Acqui Terme (AL)
 Phone: + 39 0144 445363
 Mail: info@bonominet.it
 Website: www.bonominet.it

ASK FOR JOY IT WILL BE DELIVERD IN ANY PLACE!

MANOVRE PER L'ANCORAGGIO

MANOEUVRE FOR MOORING

- 1** Posizionare la cima nel passa cima
Positioning the line in the guide line
- 2** Verifica del senso di rotazione del Self Tail
che vi indicherà il lato di posa della cima

*Check the Self Tail rotation direction that
will indicate you the line position*
- 3** Posizionare la cima lateralmente a Joy
Place the line sideways at JOY
- 4** Dare una volta attorno ai due perni rotanti
Gave once around the two rotating shaft
- 5** Tenere in tensione la cima di ritorno
Keep the line back in tension
- 6** Azionare il pulsante di comando tenendo
la cima di ritorno in tensione

*Start up the control button by holding in
tension the line back*
- 7** Eseguire il classico nodo di Galloccia per
fissare la cima a Joy

*Perform the classic cleat node to fix the line
to JOY*
- 8** Dare una volta attorno al nodo di galloccia
per sicurezza

Give once around the cleat node for security

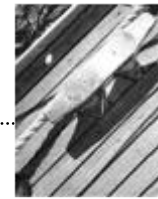

FOR MORE INFO CONTACT US

www.bonominet.it

info@bonominet.it

GRAZIE PER LA VOSTRA FIDUCIA!

THANKS FOR YOUR TRUST!

