

JOY

la Galloccia Self Tailing
the Self Tailing Cleat

Cod. n° B7A128H





B7A128H

DICHIARAZIONE CE DI CONFORMITA'
Declaration of Conformity
(Allegato IIA DIR. 2006/42/CE)



IL FABBRICANTE / THE MANUFACTURER

Bonomi S.r.l

Azienda / Company

Via Mario Pagano, 63

Indirizzo / Address

20145

Cap / Postal code

MI

Provincia / Province

Milano

Città / City

Italia

Stato / State

DICHIARA CHE LA MACCHINA / DECLARES THAT THE MACHINE

GALLOCCIA MOTORIZZATA MOD. JOY B7A128H 80KG 12V / MOTORIZED CLEAT MOD. JOY B7A128H 80KG 12V

Descrizione / Description

Matricola / Serial Number

Adatta a favorire l'ormeggio delle imbarcazioni / Suitable for boat mooring

Usa previsto / Intended use

Anno costruzione / Year of manufacture

SODDISFA LE DISPOSIZIONI DELLA DIRETTIVA 2006/42/CE del Parlamento europeo e del Consiglio, del 17 maggio 2006 relativa alle macchine e che modifica la direttiva 95/16/CE.

MEETS THE PROVISIONS OF THE DIRECTIVE 2006/42/EC of the European Parliament and of the Council of 17 May 2006 on machinery, and amending Directive 95/16/EC

E AUTORIZZA / AND AUTHORIZE

Cristiano Bonomi

Nominativo / Name

Via Mario Pagano, 63

Indirizzo / Address

20145

Cap / Postal Code

MI

Provincia / Province

Milano

Città / City

Italia

Stato / State

A COSTITUIRE IL FASCICOLO TECNICO / TO PROVIDE THE TECHNICAL FILE

Milano,/...../.....

Timbro e firma del responsabile
Stamp and signature of director

BONOMI srl
Soc. Unipersonale

Head Office
Via Mario Pagano, 63
20145 Milano
Italy
C.F. P.IVA IT09477540968

Facility
Via B. Salvadori, 34
15011 Acqui Terme (AL)
Italy

Contact
www.bonominet.it
info@bonominet.it



B7A128H

INDEX

pag. 8-29

MANUALE DI INSTALLAZIONE
INSTALLATION MANUAL

pag. 30-35

MANUALE D'USO E MANUTENZIONE
USE AND MAINTENANCE MANUAL

B7A128H

LEGGERE ATTENTAMENTE!
READ CAREFULLY!

B7A128H

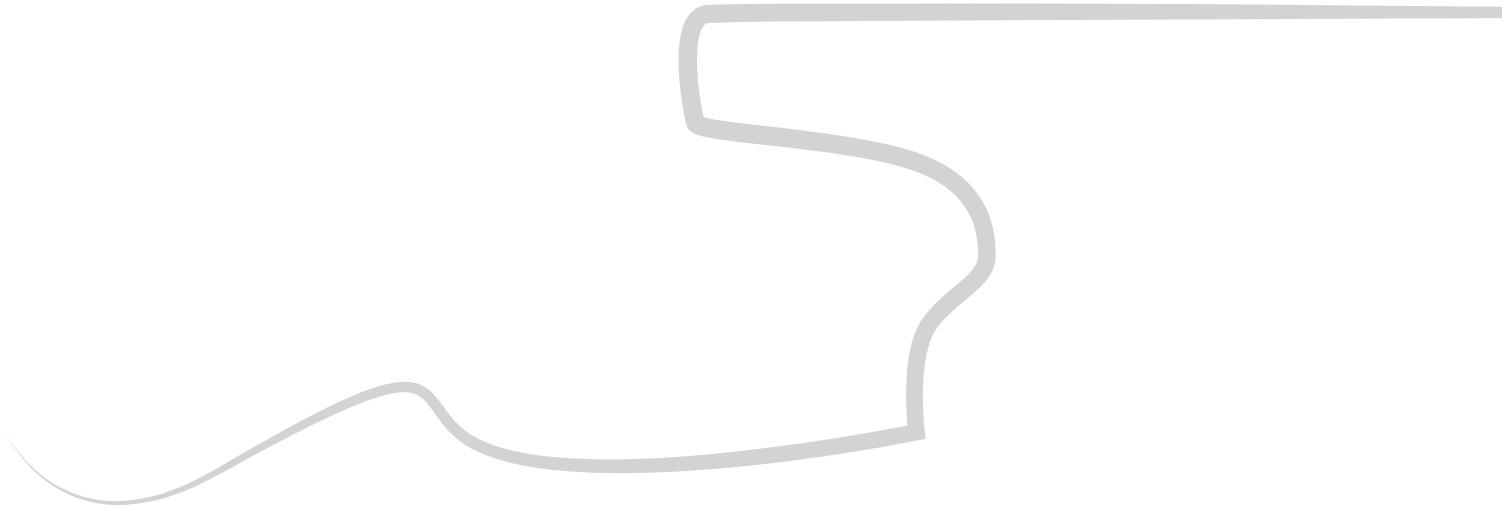



MANUALE DI INSTALLAZIONE

INSTALLATION MANUAL

B7A128H

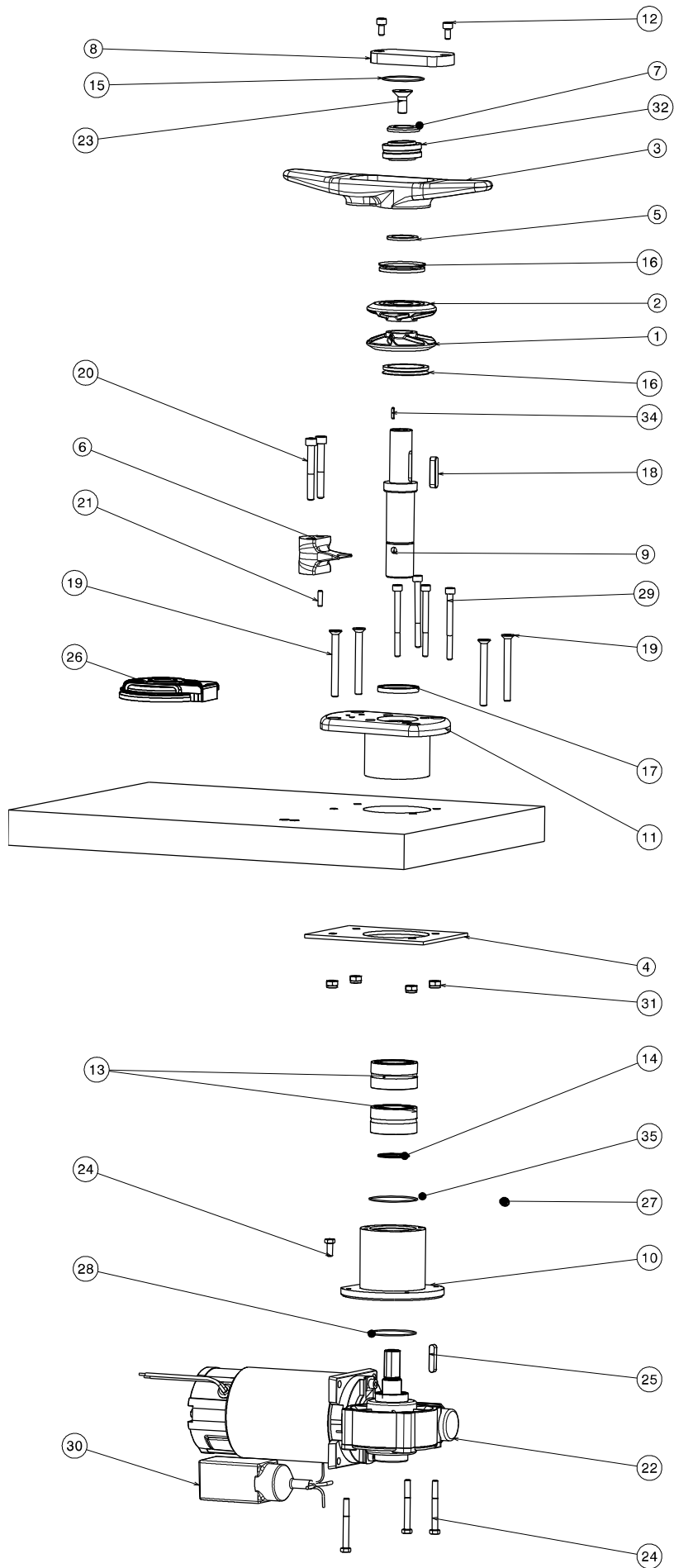

35	1	O-RING	B6A242H026
34	1	SPRING PIN	B6A242H026
33	1	HEX. HEAD SCREW ISO 4017-M5x12-A4	B1A242H090
32	1	SPHERICAL JOINT	B6A242H018
31	4	HEXAGON LOCKNUT	B6A242H022
30	1	SINGLE POLE CONTACTOR 12 Volts	
30xx	1	SINGLE POLE CONTACTOR 24 Volts	B1A242H065
29	4	SOCKET HEAD CAP SCREW	B6A242H025
28	1	O-RING	B1A242H059
27	1	GREASE NIPPLE	B1A242H050
26	1	FOOTSWITCH	B1A242H022
25	1	KEY	B1A242H020_RevA
24	3	HEX. HEAD SCREW ISO 4014-M5x45-A4	B1A242H019
23	1	SOCKET COUNTERSUNK HEAD SCREW	B1A242H014
22xx	1	MOTOR GEARBOX 12 volts	B1A242H001
22xx	1	MOTOR GEARBOX 24 Volts	B1A242H013
21	1	PIN	B6A242H024
20	2	SOCKET HEAD CAP SCREW	B6A242H023
19	4	HEXALOBULAR COUNTERSUNK FLAT	B6A242H021
18	1	KEY	B6A242H020
17	1	SEALING RING	B6A242H019
16	2	V-RIG	B6A242H017
15	1	O-RING	B6A242H016
14	1	SHAFT RING	B6A242H015
13	2	BEARING	B6A242H014
12	2	SOCKET HEAD CAP SCREW	B6A242H013
11	1	BEARING SUPPORT FLANGE	B6A242H012
10	1	MOBILE SHAFT FLANGE COVER	B6A242H011
9	1	MOBILE SPINDLE	B6A242H010
8	1	COVER wittout centering	B6A242H009
7	1	SEALING WASHER	B6A242H008
6	1	SUPPORT with SCRAPPER	B6A242H007
5	1	SPACER	B6A242H006
4	1	LOWER PLATE	B6A242H004
3	1	TOP PLATE	B6A242H003
2	1	UPPER ROPE RING	B6A242H002
1	1	LOWER ROPE RING	B6A242H001
ITEM	Q.ty	DESCRPTION	PART .NUMBER

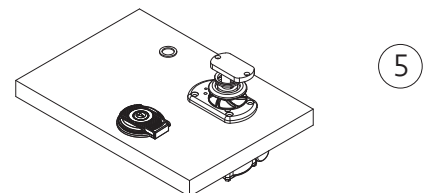
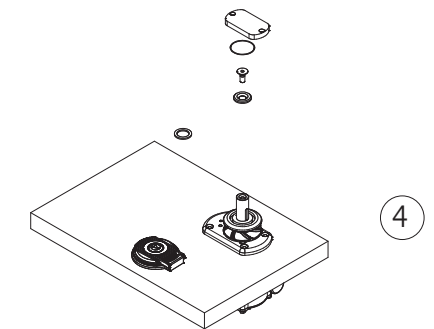
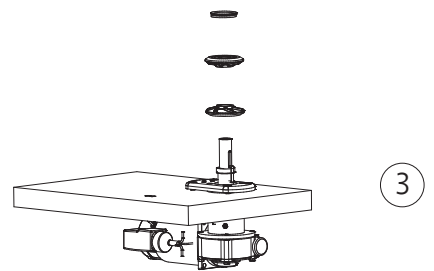
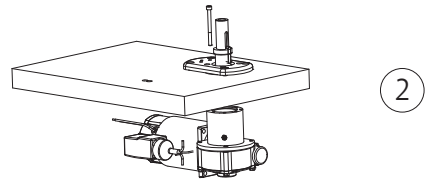
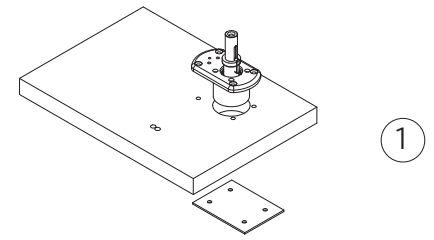

B7A128H

12 volts ASSY CLEAT COD.N. B7B128H
SEE POS. 22 FOR MOTORGEARBOX POS. 30 FOR SINGLE POLE CONTACTOR

B7A128H



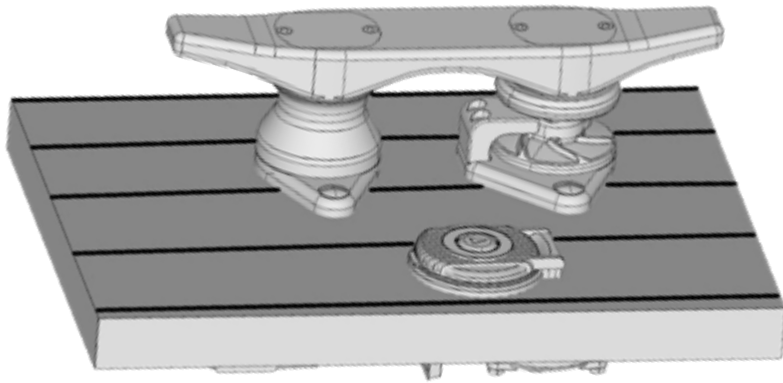

ATTREZZATURA NECESSARIA PER L'INSTALLAZIONE DI JOY

EQUIPMENT NEEDED TO INSTALL JOY

- _ Trapano elettrico professionale.
Professional electric drill.
- _ Punta da trapano per metalli
Metal drill bit Hss-R: OD 9 mm
- _ Chiave combinata per dado.
Combined wrench Key: OD 13 mm
- _ Chiave a brugola.
Allen wrench key: 5 mm
- _ Chiave a brugola.
Allen wrench key: 4 mm
- _ Cacciavite.
Screw driver : testa piatta (-)
- _ Sega a tazza
Hole saw: OD 65 mm
- _ Grasso raccomandato per cuscinetti e guarnizioni.
Reccomended Grease for bearing and gasket:
Synthetyc bearing and gear grease for nautial application:
 - SKF-LGM 2
 - Molikote
 - SMW Autoblock - K50

SUGGERIMENTI DI INSTALLAZIONE SUL PONTE

EQUIPMENT NEEDED TO INSTALL JOY

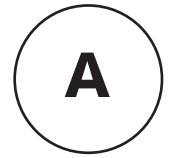

PRUA - LATO SINISTRO BOW - LEFT SIDE

NEUTRAL PULLEY

MOTOR PULLEY

SELF TAIL

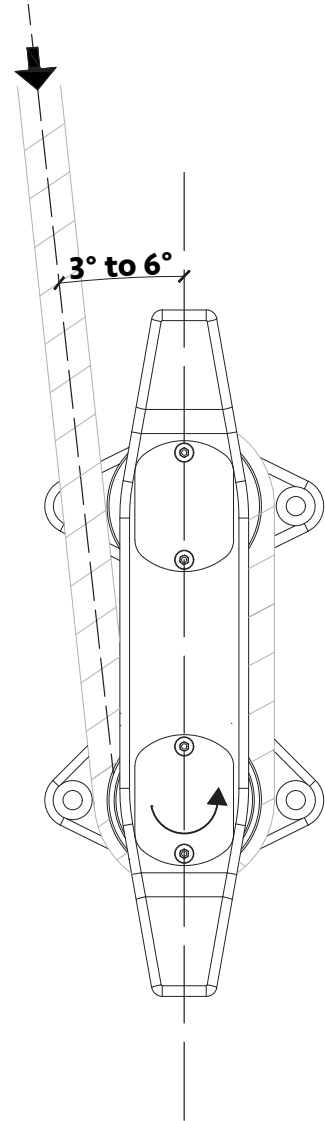

B7A128H

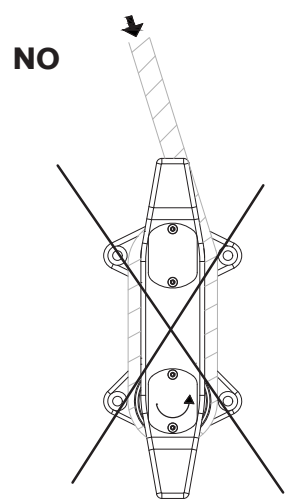
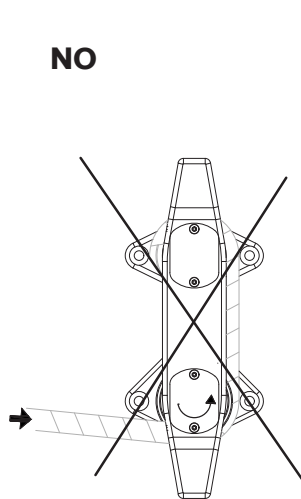
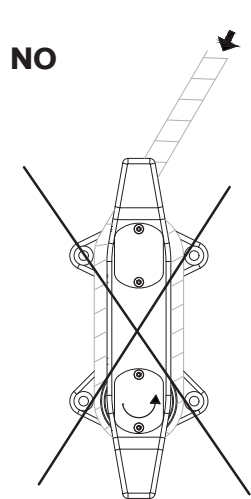
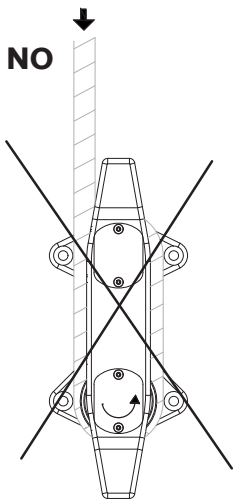

SUGGERIMENTI DI INSTALLAZIONE SUL PONTE

EQUIPMENT NEEDED TO INSTALL

B



PRUA - LATO DESTRO
BOW - RIGHT SIDE

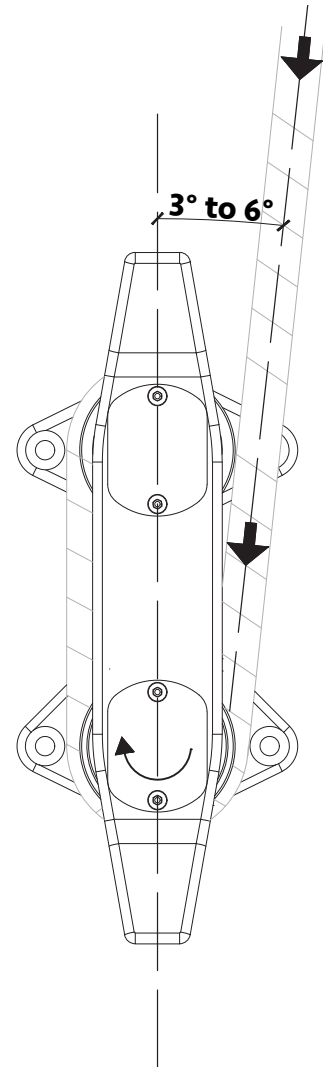
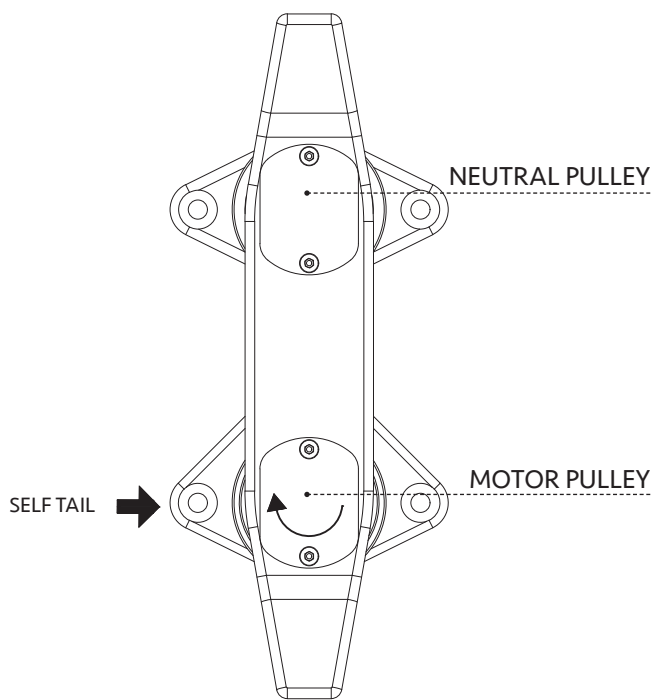

B7A128H

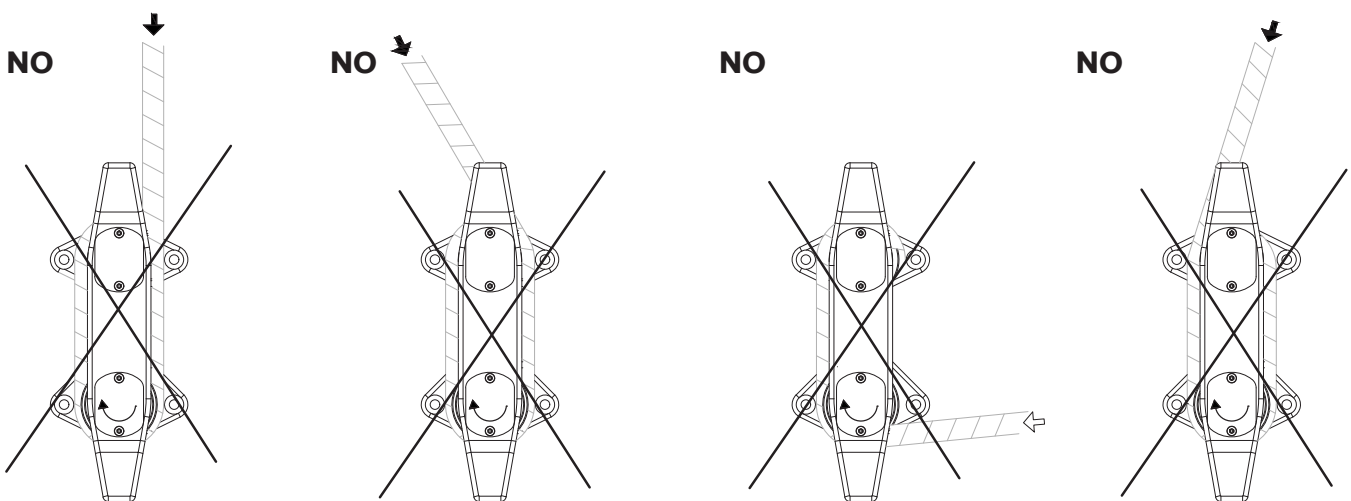

SUGGERIMENTI DI INSTALLAZIONE SUL PONTE

EQUIPMENT NEEDED TO INSTALL JOY

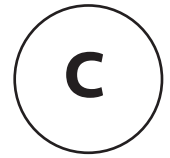

POPPA - LATO SINISTRO STERN - LEFT SIDE

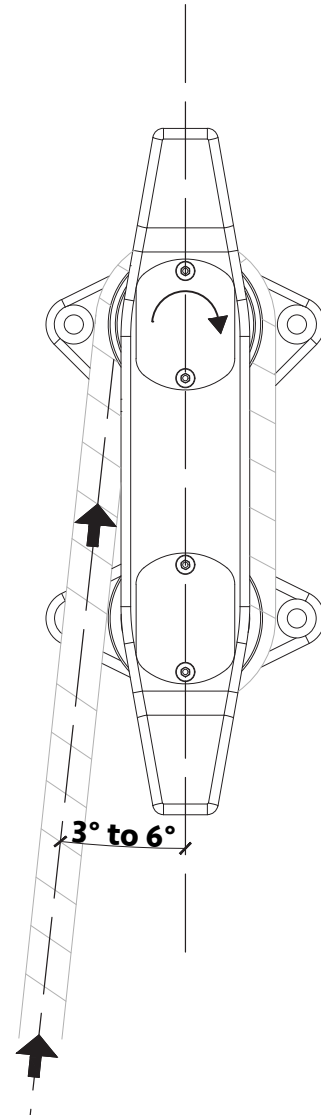
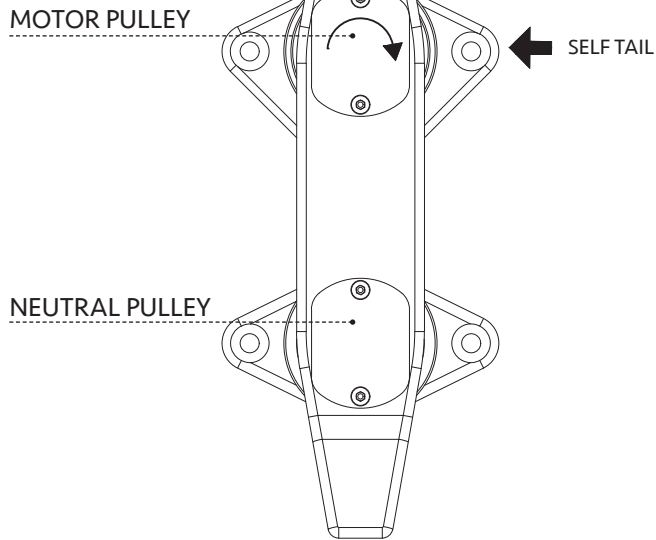
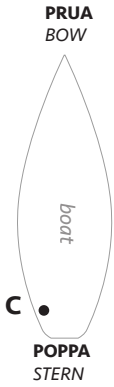

B7A128H

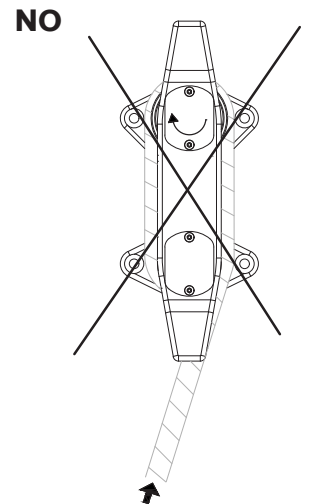
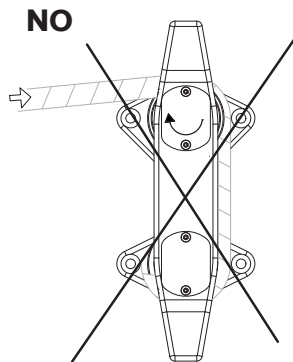
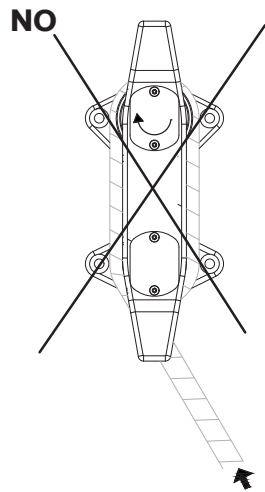
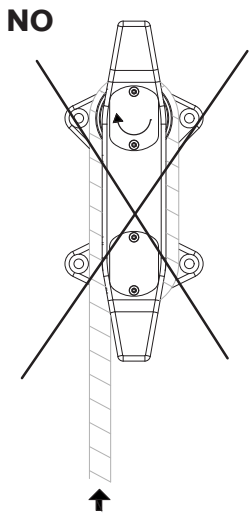

SUGGERIMENTI DI INSTALLAZIONE SUL PONTE

EQUIPMENT NEEDED TO INSTALL JOY

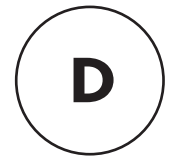

POPPIA - LATO DESTRO
STERN - RIGHT SIDE

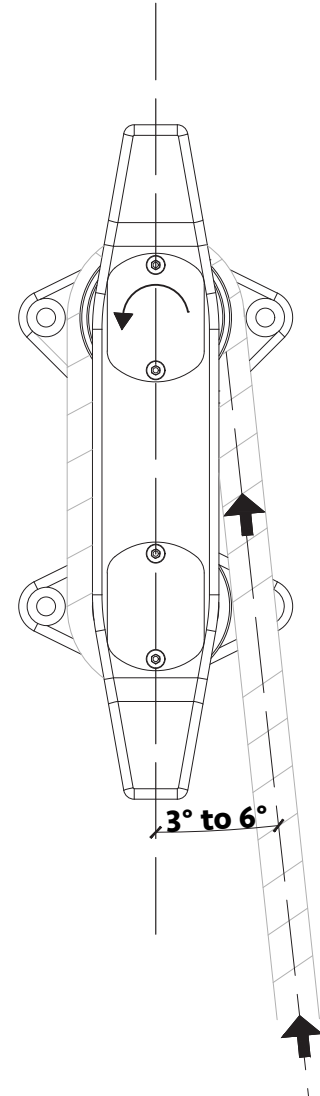
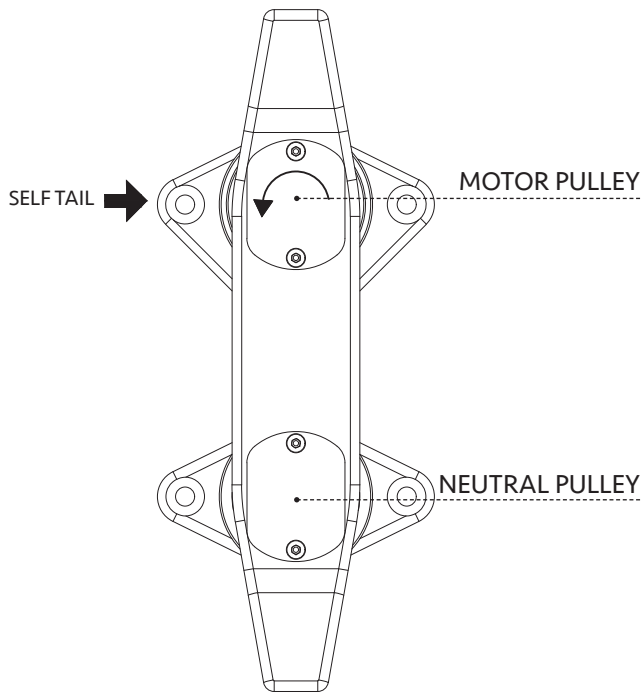

B7A128H

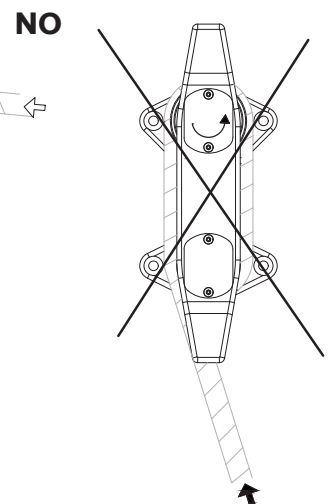
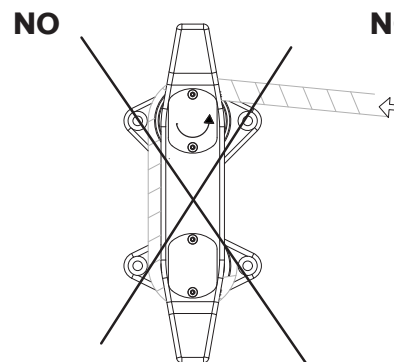
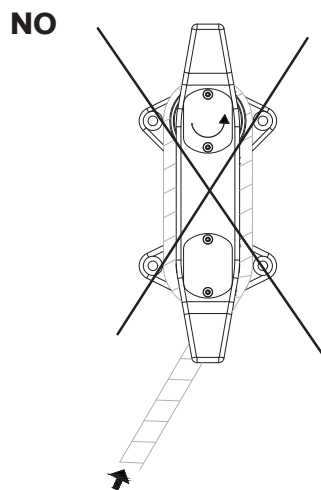
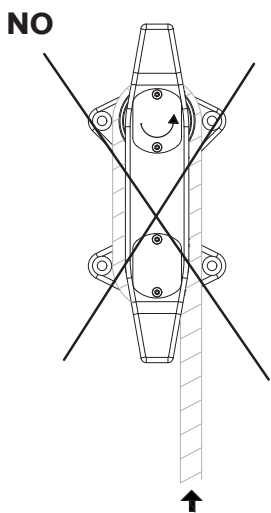

1) PREPARAZIONE E POSIZIONE

POSITION AND PREPARATION

Preparazione posizione.

Rimuovere le attrezzature vecchie e togliere tutte le asperità della zona di installazione.

NOTA: JOY è una attrezzatura elettro meccanica deve essere installata professionalmente al fine di ottenere una migliore e piu duratura vita.

Position preparation. Remove the old equipment and all the bumps in the area of installation.

NOTE: JOY is an electro-mechanical equipment must be installed professionally in order to achieve a better and more sustainable life.



2) PULIZIA PONTE PRIMA DEL MONTAGGIO

DECK CLEARING BEFORE ASSEMBLY

Il ponte deve presentare un piano liscio senza scalini o asperità, l'installazione di JOY su un ponte non piatto compromette la sua funzionalità.

The deck must have a smooth plane without steps or haze, JOY installation on a non-flat deck compromises its functionality.





3) CONTROPIASTRA DI FISSAGGIO USATA COME DIMA

COUNTERPLATE USED AS MOUNTING TEMPLATE.

NB: Il posizionamento di JOY deve essere studiato bene prima dell'esecuzione dei rispettivi fori di fissaggio sul ponte. L'asse longitudinale di Joy deve essere riferito e posizionato, in base al ponte stesso e alla direzione di arrivo della cima di ormeggio.

NB: JOY positioning must be well studied before the respective fixing holes on the deck are executed. Joy's longitudinal axis must be reported and positioned, according to the deck itself and the direction of arrival of the mooring line.

IMPORTANTE:

Il posizionamento e i fori sul ponte sono due passaggi fondamentali! Siete pregati di pensare molto bene al posizionamento della vostra JOY sul ponte prima di eseguire i fori!

IMPORTANT:

positioning and holes on the deck are two fundamental steps! Please think very well about positioning your JOY on the deck before running the holes!



**!! NOTA IMPORTANTE
PAG. 12,13,14,15**

*SEE IMPORTANT NOTE
PAGE 12,13,14,15*

4) ESECUZIONE DEI 4 FORI PERIMETRALI PER FISSAGGIO JOY

EXECUTION OF 4 PERIMETER HOLES FOR FASTENING JOY TO THE DECK.

NOTE

Prima di forare il ponte assicurarsi di aver ben compreso e ragionato sulla posizione dei fori.

Before drilling the deck make sure you well understand the positioning of the hole you are doing.



B7A128H

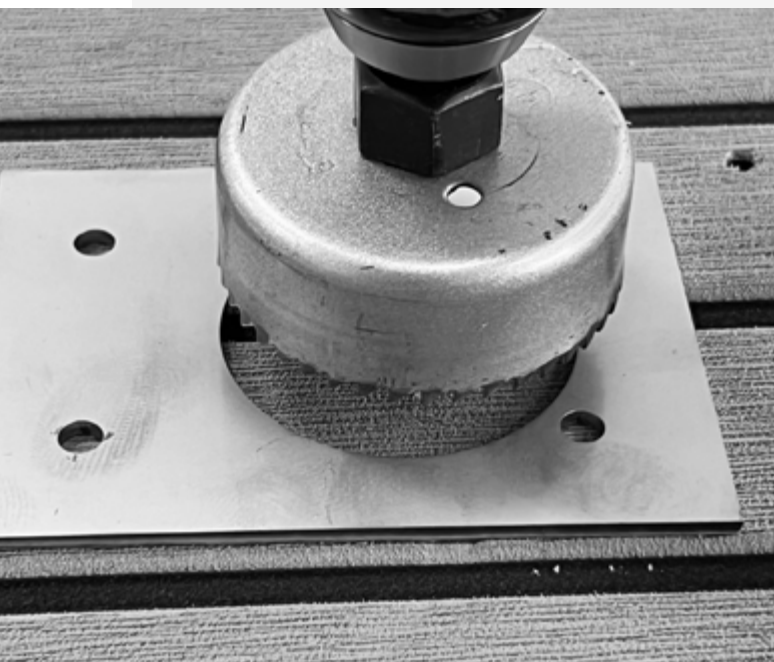

5) FORO CENTRALE PER ASSE MOTORE

CENTRAL HOLE FOR MOTOR AXIS

Prima di forare il ponte assicurarsi di aver ben compreso e ragionato sulla posizione dei fori.

Before drilling the deck make sure you well understand the positioning of the hole you are doing

B7A128H



6) POSIZIONAMENTO SOTTO IL PONTE DELLA CONTRO PIASTRA DI FISSAGGIO

UNDER DECK CONTERPLATE POSITIONING

Per fissarla temporaneamente vi suggeriamo di utilizzare una vite di posizione ①9.

To fix it temporary, we suggest you to utilize and screw of positioning ①9.



**7) POSIZIONAMENTO MOTORIDUTTORE
PREASSEMBLATO SOTTO COPERTA**

*PRE-ASSEMBLED POSITIONING GEARMOTOR
UNDER DECK*



**8) FISSAGGIO A BULLONI DEL MOTORIDUTTORE
ALLA COPERTA TRAMITE PARTE SUPERIORE PRE
ASSEMBLATA**

*FIXING THE GEARMOTOR TO THE DECK VIA THE
FIRST UPPER BASE WITH SCREW*



B7A128H

9) FISSAGGIO A BULLONI DEL MOTORIDUTTORE CON LA PARTE SUPERIORE ALLA COPERTA

FIXING THE GEARMOTOR BOLT TO THE UPPER DECK PART

Utilizzare viti di posizione (29).

Utilize screw of position (29).



Inserire PIN metallico in dotazione per montare lo stripper in pos (11)
Insert the metallic PIN to install the stripper in pos. (11)

10) INSERIMENTO SELF TAIL INFERIORE

LOWER SELF-TAIL POSITIONING

Il Self Tail è munito di guarnizioni di tenuta in gomma vulcanizzata, è buona cosa spalmare con grasso apposito suggerito.

NOTE: I Self-Tail sono studiati per essere montati in coppia e orientati in base alla rotazione del motore per avere la cima di ritorno orientata verso il centro dell'imbarcazione o verso l'esterno in tutte e due i casi JOY non perde la funzionalità.

NB: Ragionare bene sul senso di rotazione del Self Tail in funzione del rimando della cima.

The Sel-Tail is fitted with vulcanized rubber sealing gasket, good thing is spread with a special recommended gear grease.

The Self-Tail are designed to be mounted in pairs and oriented to the rotation of the motor to have the return rope oriented towards the boat center or outdoors in all case JOY not lose functionality.

NB: Think very well about the direction of the self tail rotation as a function of the rope back direction



B7A128H

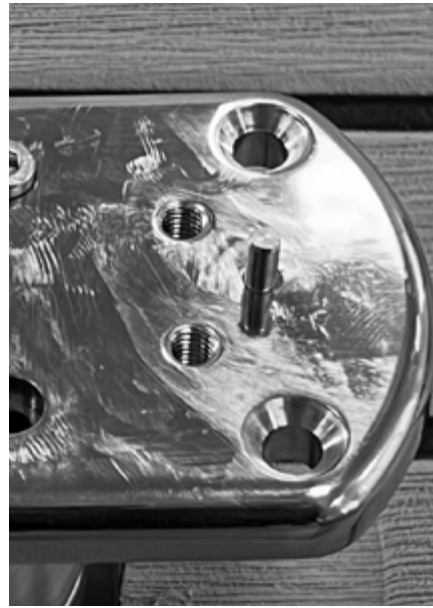

11) POSIZIONAMENTO STRIPPER

LINE STRIPPER POSITIONING

Ricordarsi di posizionare la spina
Remember to fit the pin



12) INSERIMENTO SELF-TAIL SUPERIORE

UPPER SELF-TAIL POSITIONING

Il Self Tail è munito di guarnizioni di tenuta in gomma vulcanizzata è buona cosa spalmare con grasso suggerito.

La mancanza di grasso compromette la durata delle guarnizioni

The Sel- Tailing is fitted with vulcanized rubber sea- ling gasket good thing is spread with a special recommended grease.

Lack of grease compromises the life of the gasket.



13) INSERIMENTO DEL TOP PLATE

INSERT OF THE TOP PLATE

L'inserto dell'asse motore sul giunto sferico deve essere fatto con attenzione, pulendo e ingrassando le parti con il grasso raccomandato.

The drive shaft insert on the spherical joint must be done carefully, clearing and greasing the parts with the recommended grease.

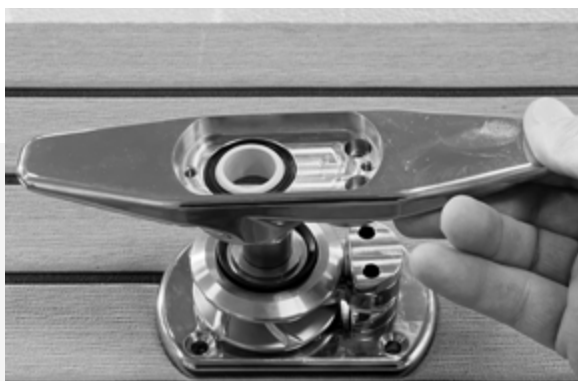

B7A128H



14) BLOCCAGGIO STRIPPER ARM ALLA BASE CON VITI DI POSIZIONE (20)

*STRIPPER ARM LOCK
AT THE BASE WITH SCREW OF POSITION (20)*



**15) INSERIMENTO SPINA ELASTICA
ANTI ROTAZIONE RONDELLA DI TENUTA**

*WASHER ANTI-ROTATION ELASTIC PIN,
TO BE INSERT BEFORE FIT THE SCREW*

**16) COLLEGAMENTO E FISSAGGIO ALL'ALBERO
CONNECTING AND FITTING TO THE SHAFT**

NB: La manovra di serraggio delle viti in posizione ②③ deve essere eseguita dopo la manovra indicata al punto 15) e prima della manovra indicata al punto 17).

NB: the fixing of the screws in position ②③ must be carried out after the maneuver indicated in steps 15) and before the maneuver indicated in step 17).



NB! I due fori di fissaggio del corpo coperchio sono filettati M5 per consentire la futura estrazione, senza danneggiare il coperchio apposito.

The two fixing hole of the cover are M5 threaded to allow the future extraction without damaging the cover

17) CHIUSURA CUSCINETTO DI ROTAZIONE.

ROTARING BEARING CLOSURE

Riempire le parti con grasso suggerito, prima della chiusura del giunto sferico con il coperchio apposito tramite viti di posizione (12).

NB: Questa manovra può anche essere eseguita al termine.

Fill the part with the recommended grease before closing the spherical joint, with the cover using screw of position (12).

NB: This operation could be done also at the end.



B7A128H



18) PRIMA DEL SERRAGGIO ALLA COPERTA INSERIRE UNA GUARNIZIONE LIQUIDA

INSERT A LIQUID GASKET BEFORE TIGHTENING TO THE DECK

Suggeriamo per praticità di posizionare la guarnizione liquida (tipo sikaflex) alla fine del montaggio e prima di serrare le quattro viti di posizione (19).

We suggest you to position the liquid seal (for ex. sikaflex) at the end of the assembly e before fixing the four screw of position (19).

19) SERRAGGIO FINALE ALLA COPERTA

FINAL FIXING TO THE DECK

Prima del serraggio delle viti di posizione ⑲ applicare la guarnizione liquida tra JOY e il ponte. Questa manovra può essere eseguita anche dopo il punto 9) o anche 13) o anche 14)

Before fixing the screw of position ⑲, insert the liquid seal between JOY and the deck. This maneuver could be performed even after the point 9), or after the point 13), or after the point 14).

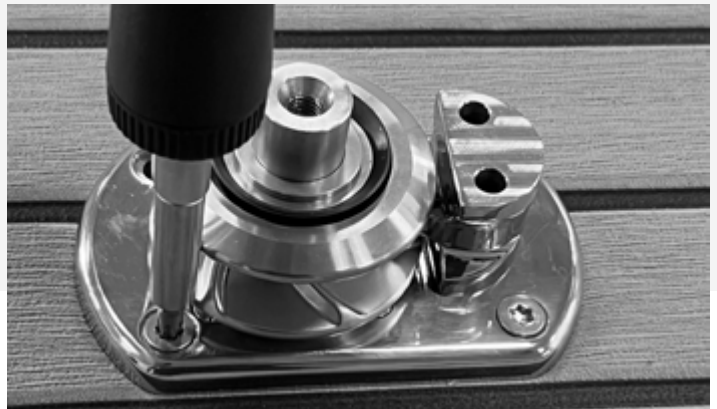

B7A128H

**GREASE
FATTENER**

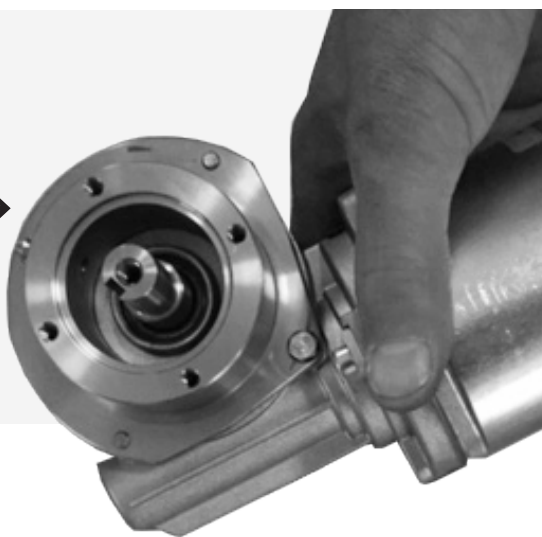

20) STEP FINALE

FINAL STEP

Al termine, ingrassare a pieno l'albero rotante tramite apposito ingrassatore usando grasso blu marino.

At the end, full fill the rotating shaft via fattener with the recommended gear grease.

COLLEGAMENTO ELETTRICO SECONDO SCHEMA

ELECTRICAL CONNECTION ACCORDING TO SCHEME

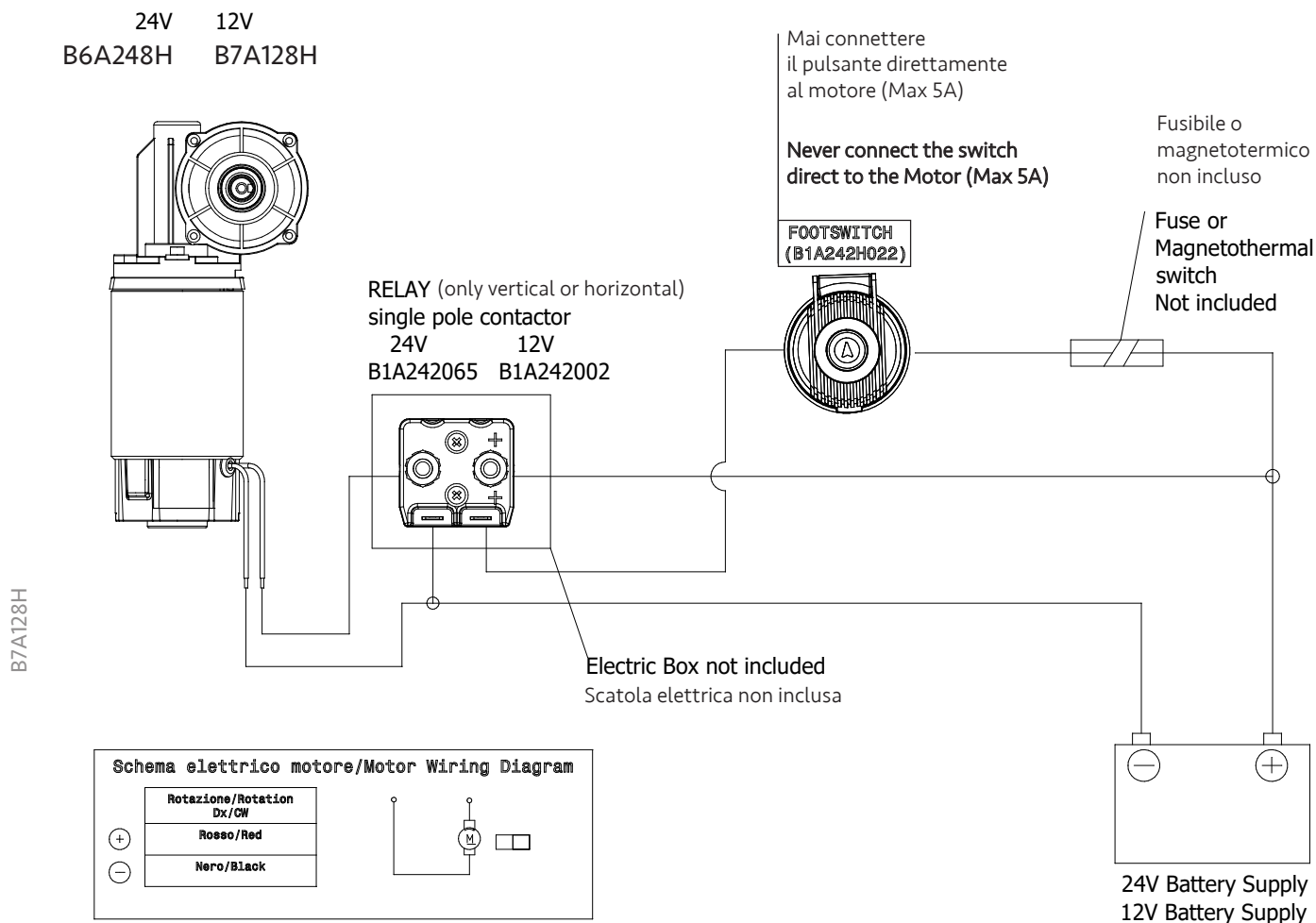

ATTENZIONE IMPORTANTE!

Durante l'ancoraggio a cima tesata e quindi a tensione massima, non insistere con il pulsante di comando, potreste danneggiare irreversibilmente il motore o altri apparati elettrici!



IMPORTANT WARNING

While mooring and when the line will be tensioned to the max, do not insist switching on the electrical power, you could damage the motor and or other electrical equipment!

ENJOY WITH JOY

Complimenti avete installato la vostra JOY correttamente e da ora in avanti la utilizzerete per i Vs ormeggi senza piu tirare le cime sino a farvi venire o il mal di schiena o di mani.

Congratulation you installed your JOY correctly, and from now on U will use it for moorings without pull the line, avoiding back and hands pain.

B7A128H

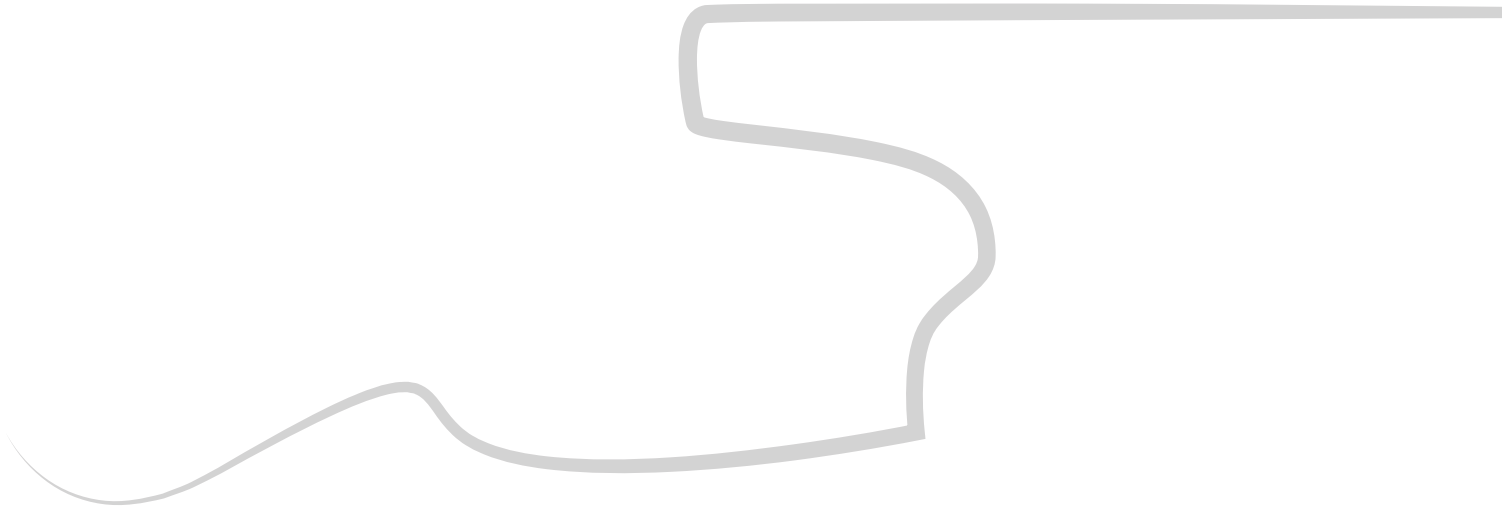



MANUALE D'USO E MANUTENZIONE

USE AND MAINTENANCE MANUAL

Manuale d'uso e Manutenzione

IMPORTANT: Please carefully read the instruction contained in this manual before putting the unit into operation

This product has been designed and produced respecting high production standards to guarantee excellent performance, convenient use and operator safety. If used with the utmost care, this product will guarantee years of optimum performance

GENERAL SAFETY RULES

ATTENZION

Carefully read all safety instructions and warnings. Failure to follow the warnings and instructions may result in electric shock, fire and serious injury.

USE FOR

This mooring motorized is equipped with a mechanical retention of the mooring line and is indicated to facilitate the maneuver of mooring in the port of the boat. This product is only suitable to favor the tension of the bow and/or stern lines of the boat and to favor the mooring phase is not to be considered as a winch or towing system.

TYPOLOGY OF USER: this product is intended for use by consumers, even non-professional maritime operators and is recommended for people of legal age.

Do not use the product for any purposes not indicated. The product should not be used as a fatigue tool. The product must not be used by children or by non-experts in the sector, the equipment is not designed for an ongoing function.

RISK TO BE READ CAREFULLY

Even indicating clearly what is the intended use for this product there are always unforeseeable residual risks. Depending on the type and construction of the product the following risks may occur:

- **Contact with rotating parts of the product, risk of abrasion and fractures**
- **Sudden and unexpected movement of the boat due to excessive tension, risk of falling, with potential fracture and abrasions**
- **Interweaving of cloche or different tops with rotating parts, risk of abrasion and potential fracture**
- **Hand skin contact, abrasion risk**
- **Keep this manual for future reference. The term "electrical appliance" used in the warnings refers to electrical appliances to be connected to the boat network, to the indicated voltage.**
- **Connections at higher voltages may cause short circuits with corresponding potential fire principles and baking of the elec-**

SAFETY IN THE WORK ENVIRONMENT

- **Keep the workplace clean and well lit. The cluttered and poorly lit spaces are source of accidents.**
- **Do not use the product in potentially explosive environments such as petrol cans or gas cylinders**
- **We suggest to think well before starting with the installation of the product that is simple, but the help of a specialized technician, electrician is strongly suggested**

ELECTRICAL SAFETY

- **Prevent the body from coming into contact with grounded metal surfaces such as power cables**
- **Do not expose the electric motor to direct water source, it favors the risk of electric shock, short circuits and fires**

PERSONAL SAFETY

- **Always remain vigilant; when using an electrical appliance, always pay attention to the operations to be carried out and always use common sense. Do not use the equipment in case of fatigue, under the effect of alcohol or drugs. Never forget that a moment of distraction is enough to cause serious injury**
- **Avoiding or minimizing involuntary start-ups due to or interlocking the footswitch or malfunctions of the system, the equipment is not designed to remain in constant motion.**
- **Before starting up the equipment and during its normal use, make sure that there are no foreign bodies that can block or compromise his operational.**
- **Do not extend the arms excessively by placing your hands close to the motorized rotating pin to prevent them from becoming involuntarily entangled in the mechanism**
- **Avoid intertwining the mooring lines with clothes, bracelets, necklaces or other that can create the situation of clinging and dragging towards the rotating motorized part**

USE AND MAINTENANCE OF ELECTRICAL APPLIANCES

- **Do not force the appliance. Use the appliance appropriate for the work to be done. The appliance will offer better performance and will be safer when used in the system for which it has designed.**
- **Do not use the appliance if the switch does not allow it to start and stop correctly. A device that can not be switched on and off properly is dangerous and must be completely repaired.**
- **Disconnect the appliance from the power supply before making adjustments or changing spare parts. These preventive safety measures reduce the risk of accidental switching on of the appliance with consequent damage to property and persons.**
- **Check the status and functionality of the electric motor to avoid electric shocks**
- **Observe the working conditions and the operations to be carried out while using the appliance. To avoid dangerous situations, use the electric appliance only for the work for which it was designed**
- **Do not underestimate that the JOY has the same function as a normal known cleat but is powered by a geared motor is therefore to be considered as a machine and as such should be treated, especially in respect of potential damage to property and especially to the people**

MAINTENANCE

- Any repairs must be carried out by a qualified technician, who, we suggest, must use only original spare parts. Maintenance requires a two year verification of rotating parts and seals; annually insert the grease indicated on the vulcanized rubber seals in order to increase its life, grease the gearmotor body every year.

GENERAL SAFETY REGULATIONS

- Before start controll the sense of rotation of the shaft in order to make the equipment work properly ·
- With the rope in the hand and not in tension, position it correctly, giving once around the two rotating pins of the equipment ·
- Position yourself with wide legs in a comfortable position in order to perform the maneuver in safety while maintaining a firm position to keep the return top stretched to facilitate maneuvering. ·
- Open the safety cover of the foot switch in order to carry out the top tension operation constantly and without interrupting it. ·
- Pay attention during the final tension phase of the rope avoiding to bring it to a condition of excessive tension and breaking, in order to avoid damage to things and especially to people.
- BE AWARE THIS IS A MACHINE CAN DAMAGE THE PEOPLE**

SPECIFICHE

Model	B7A128H
Rated Voltage In	12 VDC
Power	14
Rated Load Current	25 A
Maximum Current Draw	40 A
Duty Cycle	S2 5 min
IP Rating (Motor)	IP44
Maximum Rope Speed	6,0 M/Min
Output Shaft Speed	60 RPM
Output Shaft Torque	25-30 Nm
Load In Work On Gearbox	800 N / 80-85 kg
Insulation Class	F
Gearbox Oil	ISO 150 PAO
Tot Weight	9,5 Kg
Included Command	Single Way Footswitch
Material	Stainless Steel AISI 316 L
Mooring Line Section Range	15mm - 20mm
Vessel Length (Suggested)	30-40 ft/ 9-12 mt
Vessel Weight (Suggested)	10-15 tons

IFORMAZIONI SUL PRODOTTO

- External part AISI 316L ·
- Rotary part— secondary shaft—sealed bearing, primary shaft in grease immersion camera ·
- Motorgearbox IP 44 ·
- Connection interface coil installed in a sealed electrical box ·
- Foot switch in printed polymer IP 67 ·
- Gear motor shaft rotation parts with grease bath ·
- Seals to water on rotating parts made of high-strength vulcanized rubber

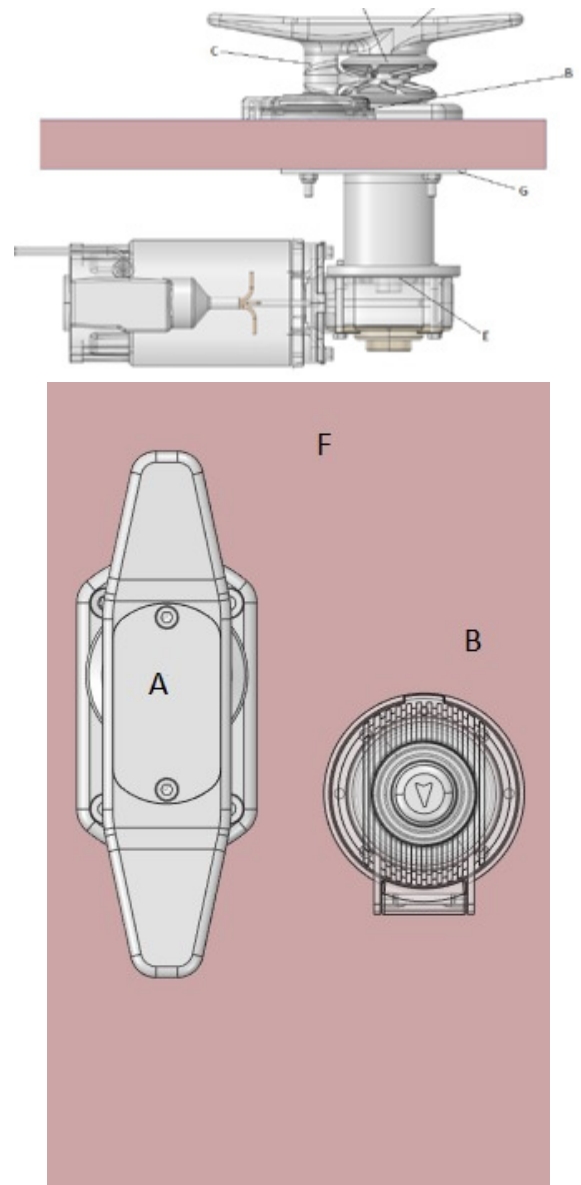

(A)	Upper deck element
(B)	Foot Switch
(C)	Neutral rotating Pin
(D)	Motorized rotating Sel Tail
(E)	Underdeck Motorgearbox
(F)	Deck
(G)	Counter Plate for appliance deck fixing

GENERAL INFORMATION

For any request, contact the technical office of Bonomi srl

Head Office: Via Mario Pagano, 63 - 20145 Milano (MI)
 Facility: Via B. Salvadori, 34 - 15011 Acqui Terme (AL)
 Phone: + 39 0144 445363
 Mail: info@bonominet.it
 Website: www.bonominet.it

ASK FOR JOY IT WILL BE DELIVERD IN ANY PLACE!

MANOVRE PER L'ANCORAGGIO

MANOEUVRE FOR MOORING

- 1** Posizionare la cima nel passa cima
Positioning the line in the guide line
- 2** Verifica del senso di rotazione del Self Tail che vi indicherà il lato di posa della cima
Check the Self Tail rotation direction that will indicate you the line position
- 3** Posizionare la cima lateralmente a Joy
Place the line sideways at JOY
- 4** Dare una volta attorno ai due perni rotanti
Give once around the two rotating shaft
- 5** Tenere in tensione la cima di ritorno
Keep the line back in tension
- 6** Azionare il pulsante di comando tenendo la cima di ritorno in tensione
Start up the control button by holding in tension the line back
- 7** Eseguire il classico nodo di Galloccia per fissare la cima a Joy
Perform the classic cleat node to fix the line to JOY
- 8** Dare una volta attorno al nodo di galloccia per sicurezza
Give once around the cleat node for security

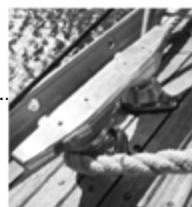

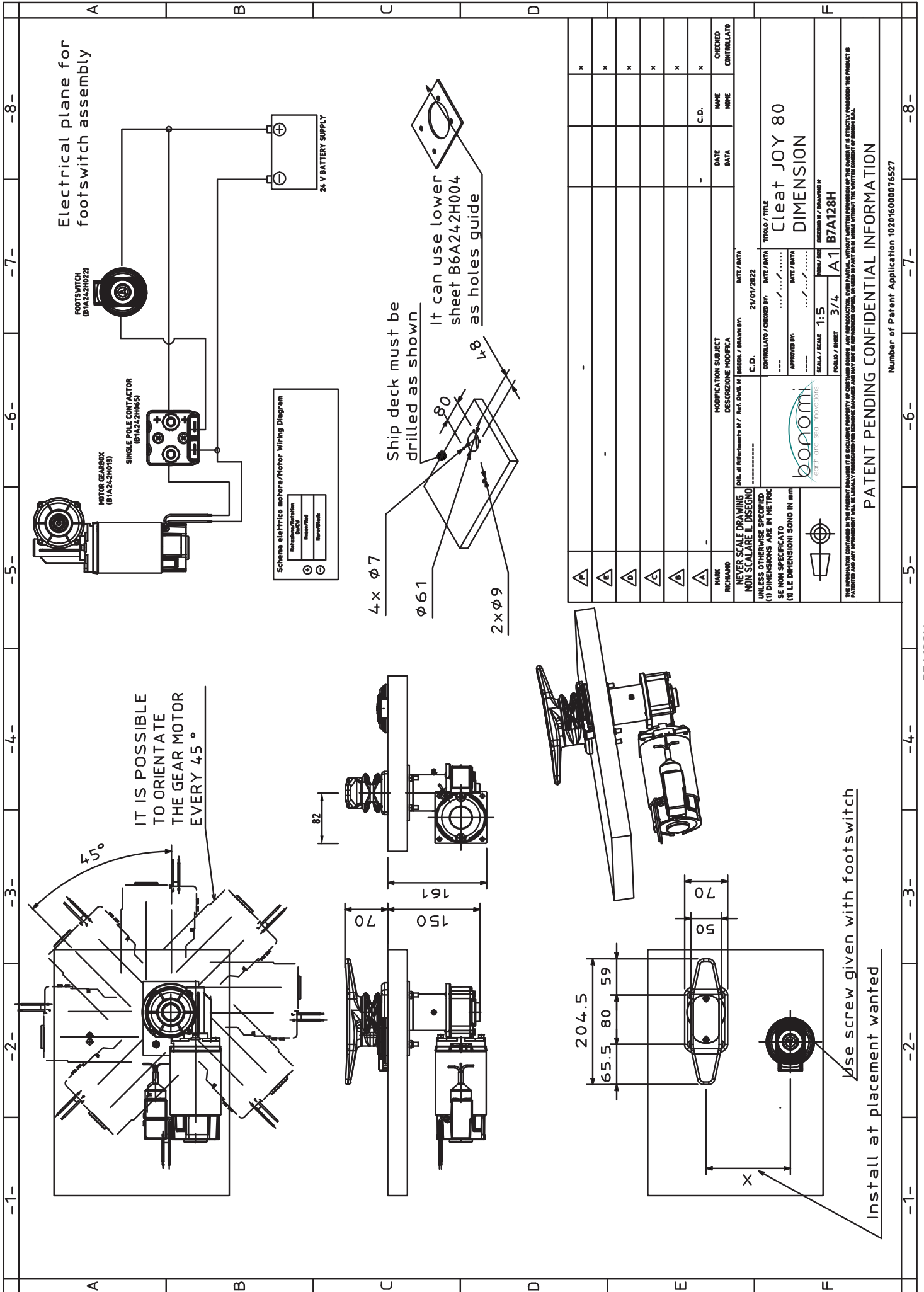

MARK	REVISIONI	MODIFICAZIONE SUBJECT	DESCRIZIONE MODIFICA	DATE / DATA	CHECKED	CONTROLLATED
A						
B						
C						
D						
E						
F						

NEVER SCALE DRAWING
NON SCALARE IL DISEGNO

UNLESS OTHERWISE SPECIFIED
SE NON SPECIFICATO
LE DIMENSIONI SONO IN MM

SCALE / SCALE: 1:5

FOOTSWITCH / DIMENSIONE P
A1 B7A128H

TITOLO / TITLE
Cleave JOY 80
DIMENSION

CONTROLLATO / CHECKED BY: DATE / DATA
21/01/2022

APPROVATO BY: DATE / DATA

REVISIONI / REVISIONES
3/4

C.D. -

MARK / MARK: C.D.

DATE / DATA

CHECKED / CHECKED

CONTROLLATED / CONTROLLATED

THE INFORMATION CONTAINED IN THIS DOCUMENT IS THE PROPERTY OF BOA ROM S.P.A. AND IS STRICTLY CONFIDENTIAL. THE PRODUCT IS PATENTED AND ANY REPRODUCTION OR USE WITHOUT THE WRITTEN CONSENT OF BOA ROM S.P.A. IS PROHIBITED.

Number of Patent Application 102016000076527

FOR MORE INFO CONTACT US

www.bonominet.it

info@bonominet.it

GRAZIE PER LA VOSTRA FIDUCIA!

THANKS FOR YOUR TRUST!

